

Measuring water levels in wells

It is important to measure the water level in your wells on a regular basis. Doing so will allow you to identify and diagnose well-production issues long before they cause serious problems such as water outages and pump damage. Besides, state drinking water rules require all water systems to maintain records of static well-water levels on a seasonal basis, including low demand and high demand periods (WAC 246-290-415(9)).

Issues that cause reduced well production include:

- ◆ Bacterial growth or mineral encrustation that plug well casing slots or screens.
- ◆ Over-pumping or drought conditions that cause a regional drop in the aquifer level.
- ◆ Problems with the operation of the well pump or pump motor.

If a utility does not track water level data over time and well production drops dramatically, the contractor hired to fix the well can only guess the nature of the underlying problem. Guesswork often leads to money wasted on a trial-and-error approach to rehabilitating the well.

The right time to measure the well water level

Measure the **static water level** and the **pumping water level** weekly during the highest water use times of the year, and at least monthly during the rest of the year. Collecting this data over a number of years will reveal any seasonal variations to water levels in the aquifer, and show trends on how the well performs when the pump is running the most.

- **Pumping water level** is the depth of the water in the well when the pump is on.
- **Static water level** is the depth of the water in the well when the pump is off long enough for the aquifer to return to its normal level. A good time to measure static water level is early in the morning before customers use much water. Surrounding water uses and seasonal weather patterns affect the static water level.

A drop in the pumping water level when there is no drop in the static level may reveal the well is not allowing water in. This could mean the slots or screen are plugged. A lower discharge rate from the pump and a higher pumping water level could mean a problem with the pump.



Todd Shepherd, water quality specialist for Tacoma Water, uses an electric water level probe to measure the water level in Well 6B.

Photo courtesy of Tacoma Water.

What to do if you are losing pumping capacity from the well

- Inform your customers. If necessary, implement a water conservation plan to decrease usage.
- Hire a licensed well driller or pump contractor to give you a professional assessment of the severity of the problem.
- Contact the local health department and the Office of Drinking Water. Ask for information about emergency sources of water.
- Take precautions if the pump is drawing air into the system. This may mean the water level dropped (at least for a little while) below the pump intake. Pumping too much air for too long can burn out a pump. If the pump circuit breaker repeatedly trips, this may also indicate that the pump has overheated from pumping air.

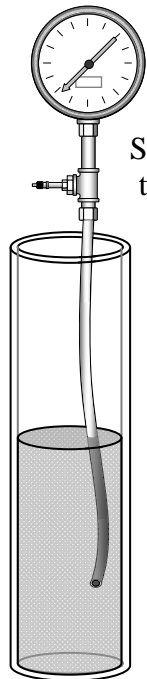

Ways to measure the water level

Air Line Device

Set a known length of small-diameter tubing down the well until at least 10 feet is in the water. The tubing must be straight, so most engineers strap it to the pump discharge pipe. Connect a pressure gauge to the tubing at the wellhead, and pump air into the line until you achieve maximum pressure. Use the pressure gauge reading to determine the length from the water level to the bottom of the tubing. Subtract this length from the total length of the air line to determine the distance from the wellhead to the water level. If the gauge is calibrated in feet, it will directly indicate the distance from the water level to the end of the air line. If the gauge reads in pounds per square inch (psi), convert the reading to feet by using the formula 1 psi = 2.31 feet.

Example: If the open end of an installed air tube is 300 feet below the top of the well casing and the pressure gauge reads 38 psi, the water level depth would be 213 feet below the top of the well casing.

$$300 \text{ feet} - (38 \text{ psi} \times 2.31 \text{ ft/psi}) = 213 \text{ feet}$$

Air Line Device

Electric Water Level Probes

Electric water level probes consist of a spool of dual conductor wire, a probe attached to the end and an indicator. When the probe contacts the water, the circuit closes and a meter light or audible buzzer attached to the spool signals contact. Read the depth from graduated markings on the wire.

Remember to:

- Disinfect the measuring device with a dilute chlorine bleach solution before using it to prevent contaminating your well. Make sure the instrument is working by dipping the probe into a bucket of clean water.
- Slowly lower the probe down the well casing. If the probe gets caught up on wires, pipes or other material in the well, pull back and try again. You may need to try several times before finding a free path down to the water.

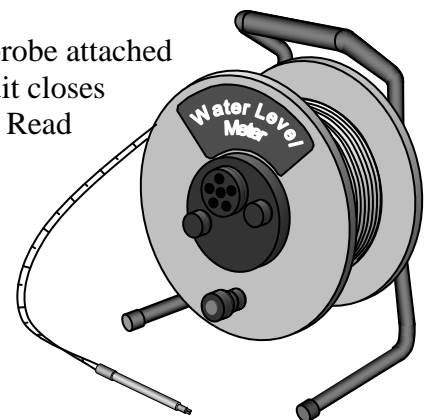

Electric Water Level Probe

- If the probe gets stuck, leave it hanging in place. Don't cut it off and let it fall into your well because it could damage the pump. Tie the measuring probe securely to the top of the wellhead and retrieve it next time you pull the pump out for maintenance or repair.
- When the electronic indicator light or buzzer signals that you've reached the water, mark the cable at the top of the well casing, and record the depth-to-water results.

Pressure Transducers

Pressure transducers are submersible sensors that measure the pressure of the column of water above them in the well and send information to above ground data loggers. They continuously record water levels.

Sonic Well Sounders

Sonic well sounders use sound waves to measure the depth to water level by bouncing sound waves off the surface of the water. Sonic well sounders are simple to use and provide instant data. There is no risk of contaminating the well because nothing touches the water and there are no probes or wires to hang up.

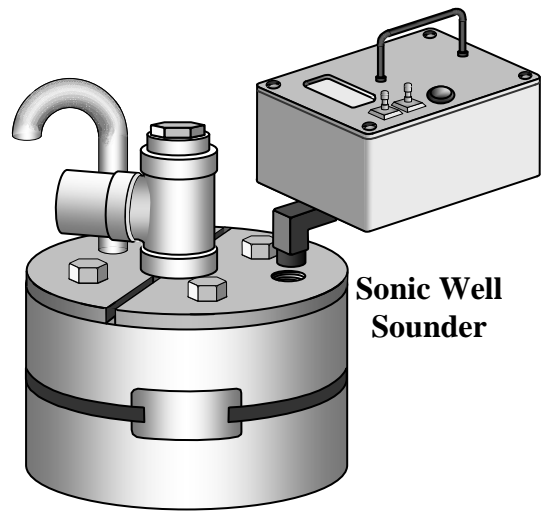

Wetted Steel Tapes

You can measure the depth of water by lowering a wetted steel tape to into the well until the lower part of the tape is under water. A chalk coating on the last few feet of tape indicate the exact water level. When you remove the tape from the well, you can read the depth of the water directly from the dry length of tape.

For more information:

Call the Office of Drinking Water at (800) 521-0323 or the:

- Southwest Region, Tumwater (360) 236-3030
- Northwest Region, Kent (253) 395-6750
- Eastern Region, Spokane (509) 329-2100

Visit the following Web sites:

Department of Health, Office of Drinking Water: <http://www.doh.wa.gov/ehp/dw>

Department of Ecology for well logs: <http://www.ecy.wa.gov/programs/wr/wells/wellhome.html>



The Department of Health is an equal opportunity agency. For persons with disabilities, this document is available on request in other formats. To submit a request, please call 1-800-525-0127 (TTY 1-800-833-6388). For additional copies of this publication, call 1-800-521-0323. This and other publications are available at <http://www.doh.wa.gov/ehp/dw>