

LOSS Rule Foundation Document

From Committee Recommendations, Consistency with Small System Rules, Staff Recommendations

	<i>Topical Areas</i>
3	Purpose and Administration
3	▪ Purpose, Objectives and Authority
3	▪ Administration
3	▪ Applicability
4	Approval & Permitting Process
4	▪ General Requirements
5	▪ Preconstruction - Pre-Design Document
6	▪ Preconstruction - Engineering Report
9	▪ Preconstruction – Plans and Specifications
10	▪ Preconstruction – Management Plan
11	▪ Preconstruction – Operation and Maintenance Manual
12	▪ Construction
13	▪ Post-Construction
14	▪ Operating Permit
16	Design & Technical Standards
16	▪ Location
18	▪ Soils and Site Evaluation
19	▪ Design Requirements - General
22	▪ Design Requirements – Soil Dispersal Component
24	▪ Design Requirements – Facilitate Operation, Monitoring, and Maintenance
24	▪ Sewage Tanks
24	▪ Design, Construction, and Specification Standards
24	▪ Collection Systems & Piping
24	▪ Monitoring Ports
25	Specific Technologies
25	▪ Pressure Distribution
26	▪ Subsurface Drip Systems
27	▪ Intermittent Sand Filters
28	▪ Sand Lined Trenches
29	▪ Recirculating Gravel Filters
30	Specific Requirements
30	Operation, Monitoring, and Maintenance- Owner Responsibilities
--	Connection to Public Sewer Systems
--	Holding Tank Sewage Systems
30	Repair of Failures
30	Expansions
--	Abandonment
--	Septage Management
	Fees

	<i>Topical Areas</i>
--	Other
--	Policy Advisory Committee
--	Waiver of State Regulations
--	Appeals - Notice of Decision – Adjudicative Proceeding
--	Enforcement
--	Severability
31	Definitions

Legend

Yellow Highlight = Changes made due to LOSS legislation

Bold and Italicized = Topics that have issues/questions that need addressing (except for topical areas in page headings)

PURPOSE AND ADMINISTRATION

PURPOSE AND ADMINISTRATION	
<i>Purpose, Objectives, and Authority</i>	
Purpose – protect public health & the environment by minimizing:	<ul style="list-style-type: none"> ▪ Potential of exposure of public to sewage from LOSS ▪ Adverse affects that LOSS discharges have on ground and surface water
The LOSS WAC:	<ul style="list-style-type: none"> ▪ Regulates LOSS to achieve long-term sewage treatment and limit discharge of contaminants to state’s waters ▪ Is adopted by Department under authority of RCW 70.118B.020 ▪ Intends to comply with designer and engineering statutes and statutes requiring coordination with Ecology ▪ <i>Intends to comply with land use and growth management statutes (Chapters 36.70 and 36.70A RCW) and the subdivision statute (Chapter 58.17 RCW)</i>

PURPOSE AND ADMINISTRATION	
<i>Administration</i>	
Department administers:	<ul style="list-style-type: none"> ▪ Under authority in Chapters 43.70 and 70.118B RCW

PURPOSE AND ADMINISTRATION	
<i>Applicability</i>	
Rule applies to:	<ul style="list-style-type: none"> ▪ On-site sewage systems (discharge is into the soil via a soil dispersal component) at any common point handling between 3,500 and 100,000 gallons/day, excluding lagoons ▪ Sources other than residential, except industrial, if treatment and dispersal provided is equal to or better than required for residential
Rule does not apply to:	<ul style="list-style-type: none"> ▪ LOSS greater than 100,000 gallons/day at any common point ▪ All systems using lagoons, regardless of discharge ▪ All wastewater treatment systems with the final discharge into surface water or on to the surface of the soil (land application) ▪ Any sewerage system that receives industrial wastewater ▪ Stormwater or combined stormwater/sanitary sewer regardless of discharge ▪ Reclaimed water systems

APPROVAL AND PERMITTING PROCESS

Approval & Permitting Process	
<i>General Requirements</i>	
Prior to construction, need:	<ul style="list-style-type: none"> ▪ One copy of the pre-design document ▪ Three copies of engineering report ▪ Three copies of plans and specifications ▪ A management plan ▪ Operation and maintenance manual ▪ Written and signed statement by owner that owner agrees to: <ul style="list-style-type: none"> ○ Use qualified installer ○ Employ a professional engineer to develop all documents, except reports done by other licensed professionals (e.g. hydrogeologist) ○ Employ qualified operator for life of system ▪ Fee
Prior to using, need:	<ul style="list-style-type: none"> ▪ Notification to DOH that installation is ready for final inspection ▪ A construction report ▪ A record drawing ▪ Final O&M manual ▪ Operating permit obtained from DOH
DOH will:	<ul style="list-style-type: none"> ▪ Send letter of approval of preconstruction documents, along with operating permit application ▪ Not change terms of approval for at least two years ▪ May allow one-year extensions if conditions met ▪ Conduct final inspection upon notification of construction completion

APPROVAL AND PERMITTING PROCESS

Approval & Permitting Process	
<i>Preconstruction: Pre-design Document</i>	
<p>Before other documents submit to DOH:</p>	<ul style="list-style-type: none"> ▪ Name, phone number, mail address, and e-mail address, if available, of applicant(s), professional engineer, legal owner(s), and any other authorized representative(s) ▪ Site address, parcel number, and/or legal description of site ▪ A brief project narrative - indicate nature of project, type of facilities to be served, other relevant information ▪ A physical description of site: <ul style="list-style-type: none"> ○ Site conditions, slope, soils, and any known limiting features, as revealed by soil survey reports, planning department documents, or an on-site evaluation ○ Detailed soil logs prepared by qualified individual prior to department's soil and site inspection ○ Estimated loading rates for soils ○ Proposed vertical separation capabilities of site ○ Total project area ○ Verification that available land area is sufficient to meet maximum daily loading requirements for both primary and reserve components ○ A map, adequate in scale and exactness, which notes available site information ○ Water sources and surface water ○ Characteristics and land use of adjacent property, as appropriate ▪ Vicinity map - provides project's location ▪ Statement of intent - source of drinking water to serve the proposed project ▪ Concept for treatment and dispersal - anticipated wastewater flows, desired design features, any planned phased development, any unique conditions that may affect the planned LOSS ▪ Proposed management entity that will provide on-going operation, monitoring, and maintenance of the proposed LOSS ▪ Application fee
<p>DOH:</p>	<ul style="list-style-type: none"> ▪ Will review the pre-design document to determine project viability ▪ If project deemed viable, will conduct soil and site inspection ▪ Will notify applicant of department's verification of site suitability and anticipated loading rates ▪ May require pre-design meeting to be held with applicant, design engineer, and department

APPROVAL AND PERMITTING PROCESS

Approval & Permitting Process	
<i>Preconstruction: Engineering Report</i>	
General Information	<ul style="list-style-type: none"> ▪ Name, phone number, mail address, and e-mail address, if available, of applicant(s), professional engineer, legal owner(s), and any other authorized representative(s) ▪ Project description, including anticipated schedule for construction ▪ Project location, site address, and tax parcel number ▪ Description of any existing system, including design criteria ▪ Source of domestic water ▪ Activity or land use of both project and adjacent area – present and anticipated
Vicinity map	<ul style="list-style-type: none"> ▪ Location of project
Area development plan drawn to scale	<ul style="list-style-type: none"> ▪ Total development, not just system area ▪ Area designated for both primary and reserve soil dispersal components, as well as other treatment and dispersal components ▪ Any surface waters or wells within 1,000 feet of soil dispersal component ▪ Structures, roads, and parking areas adjacent to proposed soil dispersal component ▪ Any on-site stormwater systems, retention basins, or drainage areas for the proposed project ▪ Location of existing and proposed encumbrances affecting system placement, including legal access documents to the property on which LOSS is to be located ▪ Contour lines drawn on intervals of no greater than 10 feet - for slopes greater than 10 percent verify by field measurements ▪ All water and sewer lines within 1,000 feet of project ▪ Location of 10-year, 25-year, and 100-year flood boundaries, if applicable - any scouring channel of stream or river should be located ▪ Drainage basins and drainage patterns throughout development site ▪ Any classified wetland within 1,000 feet of soil dispersal component
Analysis of the site's capacity	<ul style="list-style-type: none"> ▪ To treat and dispose proposed quantity and quality of sewage
Discussion of area's geology & relationship to existing ground water, site, and soil conditions	<ul style="list-style-type: none"> ▪ Depth to ground water ▪ Aquifer flow direction ▪ Aquifer's vulnerability to contamination - includes: <ul style="list-style-type: none"> ○ Existence of protective impermeable layer or aquitard ○ Water quality information if unconfined aquifer useable for potable purposes ▪ Location, capacities, & well logs for all wells and springs within 1,000 feet of proposed primary & reserve soil dispersal component ▪ Nitrate sample results from potentially influenced potable water sources within 1,000 feet from proposed soil dispersal component ▪ Identification of sensitive areas within 1,000 feet from proposed soil dispersal component – includes: <ul style="list-style-type: none"> ○ Ground or surface water used as a potable water supply source

	Approval & Permitting Process
Preconstruction: Engineering Report (continued)	
	<ul style="list-style-type: none"> ○ Critical aquifer recharge area ○ Designated wellhead protection area ○ Marine shoreline ○ Shellfish growing area ○ Wetland area under production of crops for human consumption ○ Water recreation area ○ Frequently flooded area ▪ Any federal, state, or locally protected area
Required additional information	<ul style="list-style-type: none"> ▪ Input balance analysis - demonstrates soil in soil dispersal component area is able to accept and transmit all the effluent and remain in an unsaturated condition - measurements made for most limiting time of year <ul style="list-style-type: none"> ○ Estimate all inputs (effluent, inflow, precipitation, and infiltration) ○ Estimate all outputs (evapotranspiration, horizontal and vertical conductivities, gradient) ○ Verify output is greater than input ▪ A hydrogeology report shall address: <ul style="list-style-type: none"> ○ Depth to water table ○ Current and potential importance of receiving waters to public health, including potable use, bathing, and shellfish harvesting ○ Flow, direction, and gradient of aquifer ○ Size, hydraulic conductivity, and diluting capacity of aquifer ○ Annual average precipitation and aquifer recharge ○ Nitrate sample results from any potable water sources potentially influenced within 1,000 feet from proposed soil dispersal component ○ Discussion of soil characteristics, existence of confining beds, aquitards, or restrictive layers ○ Potential for ground water mounding and its affect on available vertical separation ○ Potential for denitrification ○ Monitoring well design and construction detail ○ Details of groundwater or effluent monitoring program ▪ Nitrate balance to include: <ul style="list-style-type: none"> ○ <i>How background nitrate levels will be impacted by proposed development. To include following information, unless supporting technical information can justify to department that other values are appropriate for proposed project's site:</i> <ul style="list-style-type: none"> ▫ <i>Minimum hydraulic flow per residence is 240 gallons/day</i> ▫ <i>Minimum input value for total nitrogen for residential septic tank effluent is 50 mg/L</i> ▫ <i>Maximum denitrification expected for coarse soil is ten percent of total nitrogen discharged to it</i>

	Approval & Permitting Process
Preconstruction: Engineering Report (continued)	
Required additional information	<ul style="list-style-type: none"> ○ <i>Proposal for pretreatment for nitrogen that can be used in calculations with supporting performance testing data for proposed treatment component</i> ○ <i>Verification that background nitrate levels will not increase more than 2 mg/L</i> <ul style="list-style-type: none"> ▪ Proposal for additional treatment ▪ Ongoing effluent and/or groundwater monitoring Special management requirements
Soil and site evaluation	<ul style="list-style-type: none"> ▪ Signed and stamped by qualified evaluator
Verify compliance with other local and state regulations	<ul style="list-style-type: none"> ▪ <i>State Environmental Policy Act per RCW 43.21C and WAC 197-11 - show total project, not just the LOSS, has received approval</i> <ul style="list-style-type: none"> ○ <i>Signed declaration of non-significance from local agency with jurisdiction</i> ○ <i>Letter from agency with jurisdiction stating that final Environmental Impact Statement is acceptable</i> ○ <i>Letter from local agency with jurisdiction stating total development exempt from State Environmental Policy Act.</i> ▪ <i>If all or part in a shorelines area, a statement that total project conforms with shoreline master plans, coastal zone management plans, & flood control zone requirements.</i> ▪ <i>Comprehensive plans</i> ▪ <i>Other applicable state and local regulations relating to zoning, platting, critical areas, health, and building regulations as they relate to sewage treatment and dispersal</i>
Basis for design	<ul style="list-style-type: none"> ▪ To be used in developing the plans and specifications - design flows, hydraulic loading rate, and level of treatment needed
Construction plan	<ul style="list-style-type: none"> ▪ How project will be constructed, ingress, egress, etc.
Management overview	<ul style="list-style-type: none"> ▪ How LOSS will be managed

APPROVAL AND PERMITTING PROCESS

Approval & Permitting Process	
<i>Preconstruction: Plans and Specifications</i>	
Must contain:	<ul style="list-style-type: none"> ▪ Schematic flow diagram ▪ Location, dimensions, and elevations of all treatment and pumping units ▪ All design calculations ▪ Detailed plan and elevation/cross-section views of: <ul style="list-style-type: none"> ○ All sewage tanks (must be approved by DOH) - include detail on size, construction, materials, baffling, liquid volumes, scum and sludge volumes, pump-on and pump-off levels, emergency volumes ○ Sewage collection and transmission lines – size, materials ○ Cleanouts ○ Alarm systems ○ Flow metering ○ Valve arrangements/location ○ Soil dispersal component – width, depth, length, pipe sizes and materials, configuration, scale of 1:50 or better with contours in the drainfield area to be on no greater than two foot intervals ▪ Provisions for: <ul style="list-style-type: none"> ○ Inspection of work during construction by design engineer ○ Pre-testing of pressure distribution network ○ Scheduling of final inspection by department ▪ Verification that requirements in rule, including design and technical standards, met ▪ Specifications to include all construction information not shown on the drawing that is necessary to inform the installer of design requirements for: <ul style="list-style-type: none"> ○ Quality of materials ○ Workmanship and fabrication of the project ○ Type, size, strength, operating characteristics, and rating of equipment ○ Allowable leakage of joints, including machinery, valves, piping, and jointing of pipe ○ Electrical apparatus and wiring ○ Meters ○ Operating tools ○ Construction materials ○ Special filter or distribution materials, such as gravel ○ Miscellaneous appurtenances ○ Instructions for testing materials and equipment as needed to meet design standards ▪ Operating tests for completed works and component units

APPROVAL AND PERMITTING PROCESS

Approval & Permitting Process	
<i>Preconstruction: Management Plan</i>	
Management entity	<ul style="list-style-type: none"> ▪ <i>For development where lots or units are individually owned - a public entity as primary management entity, or as third party trust for a private management entity</i> ▪ For single owner systems - public entity or private entity. <ul style="list-style-type: none"> ○ Owner required to sign management agreement with DOH ○ Owner accepts responsibility for LOSS ○ Agreement must remain in force as long as system is in service ○ Provisions in agreement to be disclosed and transferred to new owner if property is sold or transferred
Assurance of:	<ul style="list-style-type: none"> ▪ System to be operated & maintained in accordance with rules ▪ Condition of the LOSS to be continuously monitored to assure proper functioning ▪ <u>A qualified operator will be provided, & DOH to be notified within 30 days if change in operator - considered qualified if:</u> <ul style="list-style-type: none"> ○ <u>A professional engineer or licensed designer, or</u> ○ <u>Certified to operate/maintain wastewater system by state or local agency, recognized educational institution, or professional organization</u> ▪ <u>Where proprietary treatment component is proposed, manufacturer of component must monitor and maintain proprietary system or train and authorize in writing qualified operator</u> ▪ <u>Effluent and ground/surface water monitoring</u> ▪ Adequate management, staff and facilities to be provided as necessary to manage system and keep adequate records ▪ On-going financial viability of management entity ▪ On-going legal access to system components for operation, monitoring, and maintenance ▪ Operation from fixed location - provide current contact information to the Department ▪ Record of any inspections, repairs, sampling, pumping, or improvements maintained ▪ Accounting and audit system conform with applicable statutes ▪ DOH-approved Operation and Maintenance Manual - system to be monitored and maintained in accordance with approved manual ▪ Only qualified, licensed, certified or approved professionals will be contracted for maintenance service, pumping, electrical work, etc. as needed ▪ Annual report will be submitted to department
Management entity duties	<ul style="list-style-type: none"> ▪ What management is responsible for
Controls	<ul style="list-style-type: none"> ▪ Ensure continuity and permanency of proper operation and maintenance
Methods and frequency	<ul style="list-style-type: none"> ▪ Monitoring, record keeping, and reporting to department
Rights & responsibilities	<ul style="list-style-type: none"> ▪ Of management ▪ Of persons purchasing connections to LOSS

APPROVAL AND PERMITTING PROCESS

Approval & Permitting Process	
<i>Preconstruction: Operation and Maintenance Manual (May be draft)</i>	
Ownership and Responsibilities	<ul style="list-style-type: none"> ▪ Who owns system? ▪ Who manages system? ▪ Who submits annual report and renews operating permit?
To include, but not be limited to schedules and/or procedures for:	<ul style="list-style-type: none"> ▪ <i>Response to emergencies, including provisions for:</i> <ul style="list-style-type: none"> ○ <i>Notification of users, department, and local health officer of emergency</i> ○ <i>Determination of cause of any failure or malfunction - submitted in writing to DOH</i> ○ <i>Making repairs, replacements, or modifications as required to restore proper functioning</i> ▪ <i>Periodic inspection of facilities to ascertain efficiency of operation, adequacy of performance, and general condition of equipment</i> ▪ <i>Periodic pumping of sewage tanks</i> ▪ <i>Periodic maintenance of pumps, motors, and switches</i> ▪ <i>Replacement or repair of worn or damaged equipment</i> ▪ <i>Monitoring of water use or wastewater generation volumes</i> ▪ <i>Activities that provide dosing and resting cycles for soil dispersal components</i> ▪ <i>Determination of liquid levels in trenches and/or in ground water</i> ▪ <i>Monitoring of ground water or adjacent surface water quality</i> ▪ <i>Performance sampling for all proprietary treatment components or other components as required by DOH</i> ▪ <i>Other appropriate helpful activities, depending on system type</i> ▪ <i>Sample forms for all operation, monitoring, and maintenance activities</i> ▪ <i>Record drawing in final manual</i> ▪ <i>Items from DOH guidance</i>
Provide for record keeping:	<ul style="list-style-type: none"> ▪ For all inspections, monitoring, maintenance, and changes made to the LOSS ▪ Observations and measurements for each monitoring inspection ▪ Records to be available for inspection by DOH during normal hours of business

APPROVAL AND PERMITTING PROCESS

Approval & Permitting Process	
<i>Construction</i>	
Owner to verify <u>qualified installer</u> will install LOSS	<ul style="list-style-type: none"> ▪ Certified to install on-site sewage systems by state or local agency, recognized educational institution, or professional organization ▪ Three or more years of experience installing on-site sewage systems ▪ Experience must include installation of pressure distribution systems and other alternative systems ▪ Where a LOSS product requires proprietary or public domain treatment or distribution products, other than a septic tank followed by gravel-filled SSAS, experience must include successful completion of at least one similar installation ▪ Provide at least one letter of reference from a professional engineer, LOSS owner, government agency, or proprietary manufacturer verifying the installer has successfully completed the installation of a minimum of 5 on-site sewage systems
Qualified installer must:	<ul style="list-style-type: none"> ▪ Follow approved design ▪ Have approved design in possession during installation ▪ Only install sewage tanks approved by department ▪ Be on site at all times during excavation and construction of LOSS ▪ Except for soil dispersal component, install LOSS to be watertight ▪ Cover installation only after DOH has given approval to cover ▪ Backfill and grade site to prevent surface water from accumulating over any LOSS system component ▪ Obtain approval from design engineer and DOH prior to making any substantial deviations from approved preliminary reports, plans, or specifications
Construction inspections	<ul style="list-style-type: none"> ▪ Design engineer or authorized representative to inspect per approved inspection schedule included in plans ▪ Special mandated inspections for: <ul style="list-style-type: none"> ○ Poured-in-place sewage tanks ○ More complex systems, including shallow soil dispersal component installations ○ Placement of select fill material or special excavation requirements

APPROVAL AND PERMITTING PROCESS

Approval & Permitting Process	
<i>Post-Construction Review</i>	
Prior to covering (back-filling) system, <u>design engineer</u> is to:	<ul style="list-style-type: none"> ▪ Conduct/Witness drainfield pressure test & verify function per approved design ▪ Schedule a final inspection by department (minimum five working days notice) ▪ Be present when DOH conducts their final inspection
DOH may allow:	<ul style="list-style-type: none"> ▪ Partial cover prior to final inspection if: <ul style="list-style-type: none"> ○ Gravelless chambers are used instead of gravel ○ Design engineer verified system was pretested and functions in accordance with design ○ DOH can witness pressure test at least distal orifices in each lateral during final inspection ▪ Cover of subsurface drip systems prior to final inspection if design engineer: <ul style="list-style-type: none"> ○ Conducts or witnesses pressure test ○ Records baseline flow and pressure information ○ Makes data available to DOH during final inspection
DOH will:	<ul style="list-style-type: none"> ▪ Conduct final inspection and witness pressure test ▪ Authorize cover
Within <u>60 days</u> of DOH final inspection, but prior to use:	<ul style="list-style-type: none"> ▪ Design engineer shall sign, stamp, and submit to DOH <ul style="list-style-type: none"> ○ LOSS construction report to DOH verifying construction per approved plans ○ Record drawing ○ Final O&M manual ▪ Owner/Applicant sign and submit operating permit application and applicable fees to DOH

APPROVAL AND PERMITTING PROCESS

Approval & Permitting Process	
<i>Operating Permit – LOSS must have one to use LOSS</i>	
For new LOSS	<ul style="list-style-type: none"> ▪ DOH to send operating permit application to owner with approval of preconstruction documents ▪ LOSS owner to complete, sign, & submit application & fees to DOH within <u>60 days</u> after DOH final inspection ▪ DOH to issue LOSS operating permit to LOSS owner <u>within 10 days</u> of receiving complete LOSS operating permit application and fees ▪ LOSS operating permit valid for at least one year from issue date
<i>For existing LOSS without operating permit</i>	<ul style="list-style-type: none"> ▪ <i>Chapter 70.118B RCW</i>
Renew operating permit	<ul style="list-style-type: none"> ▪ DOH to mail LOSS operating permit renewal application & annual report form to LOSS owner <u>90 days</u> prior the permit's expiration ▪ LOSS owner to update, complete, & return renewal application and an annual report to DOH within <u>30 days</u> prior to permit's expiration ▪ DOH to grant/deny renewal within <u>30 days</u> of receiving a complete and accurate renewal application & annual report
Annual report	<ul style="list-style-type: none"> ▪ Verify LOSS was operated, monitored, & maintained in accordance with O&M manual ▪ LOSS is functioning within anticipated norms ▪ To include: <ul style="list-style-type: none"> ○ Name & contact information of legal owner ○ Operating permit number ○ Site location information ○ Name and contact information of current operator ○ County ○ Dates & times monitoring & maintenance service provided ○ Observations & assessment of site ○ Sewage flows with supporting information ○ Completed monitoring/maintenance checklist for pretreatment components ○ Completed monitoring/maintenance checklist for soil dispersal components ○ <i>Effluent and/or ground/surface water sampling, if required</i> ○ Overall system condition
LOSS owners who don't return renewal documents before deadline:	<ul style="list-style-type: none"> ▪ Are not issued an operating permit prior to completing all requirements ▪ May face enforcement provisions/penalties
DOH:	<ul style="list-style-type: none"> ▪ <i>To issue/renew operating permit when all requirements met</i> ▪ <i>May impose conditions & compliance schedules when deemed necessary</i> ▪ <i>May revoke/modify existing permit or deny application if determination of public health or environmental hazard, e.g.:</i> <ul style="list-style-type: none"> ○ <i>An approved management entity ceases to operate, monitor, & maintain LOSS</i> ○ <i>Owner does not meet other conditions of operating permit</i> ○ <i>LOSS fails</i>

	Approval & Permitting Process
<i>Operating Permit (continued)</i>	
DOH:	<ul style="list-style-type: none"> ▪ <i>To evaluate & place each LOSS into an operating permit category</i> <ul style="list-style-type: none"> ○ <i>U – Unconditional operating permit</i> <ul style="list-style-type: none"> • <i>Design & installation meet all requirements</i> • <i>All reports, plans, and manuals complete and acceptable</i> • <i>Final inspection performed</i> • <i>All requirements of renewal have been met</i> ○ <i>C – Conditional operating permit</i> <ul style="list-style-type: none"> • <i>Design & installation doesn't meet all requirements</i> • <i>All reports, plans, and manuals not complete or acceptable</i> • <i>Final inspection not performed</i> • <i>All requirements of renewal have not been met</i> • <i>Compliance schedule for meeting requirements to be required</i> ▪ <i>To issue new/revised permit when:</i> <ul style="list-style-type: none"> ○ <i>Conditions resulting in category C operating permit/compliance schedule are satisfied</i> ○ <i>Conditions of Category U operating permit are not satisfied</i> <p><i>Ownership of the LOSS changes</i></p>

DESIGN & TECHNICAL STANDARDS

Design & Technical Standards	
<i>Location</i>	
Horizontal setbacks	<ul style="list-style-type: none"> ▪ Per following table ▪ Where conditions indicate greater potential for contamination or pollution, DOH may increase distances
LOSS only located where:	<ul style="list-style-type: none"> ▪ <30 % (17°) slope ▪ Soil types 1 through 5 ▪ Area not subject to: <ul style="list-style-type: none"> ○ Encroachment by buildings or construction such as placement of power poles and underground utilities ○ Cover by impervious material ○ Vehicular traffic ○ Other activities adversely affecting soil or LOSS performance ▪ Sufficient reserve area for replacement exists to treat and dispose 100% of design flow ▪ Land is stable ▪ Surface drainage is directed away from site
Other	<ul style="list-style-type: none"> ▪ If surface water is used as a public drinking water supply, LOSS to be located outside of required source water protection area ▪ Sewer transport line may be within 10 feet of water line if complies with Section C1-9 of “Criteria for Sewage Works Design”

DESIGN & TECHNICAL STANDARDS

Minimum Horizontal Separations

Items Requiring Setback	From edge of soil dispersal component and reserve area	From sewage tank and distribution box	From building sewer, and non-perforated distribution pipe
Well or suction line	100 ft.	50 ft.	50 ft.
Public drinking water well	100 ft.	100 ft.	100 ft.
Public drinking water spring measured from the ordinary high water mark	200 ft.	200 ft.	100 ft.
Spring or surface water used as drinking water source measured from the ordinary high water mark ¹	100 ft.	50 ft.	50 ft.
Pressurized water supply line	10 ft.	10 ft.	10 ft.
Decommissioned well (decommissioned in accordance with chapter 173-160 WAC)	10 ft.	N/A	N/A
Surface water measured from the ordinary high water mark	100 ft.	50 ft.	10 ft.
Building foundation/in-ground swimming pool	10 ft.	5 ft.	2 ft.
Property or easement line	5 ft.	5 ft.	N/A
Interceptor / curtain drains/ foundation drains/drainage ditches			
Down-gradient ² :	30 ft.	5 ft.	N/A
Up-gradient ² :	10 ft.	N/A	N/A
Other site features that may allow effluent to surface			
Down-gradient ² :	30 ft.	5 ft.	N/A
Up-gradient ² :	10 ft.	N/A	N/A
Down-gradient cuts or banks with at least 5 ft. of original, undisturbed soil above a restrictive layer due to a structural or textural change.	25 ft.	N/A	N/A
Down-gradient cuts or banks with less than 5 ft. of original, undisturbed, soil above a restrictive layer due to a structural or textural change.	50 ft.	N/A	N/A
Other adjacent soil dispersal components (including individual beds or SSAS sectors) [From: RDC recommendation]/subsurface stormwater infiltration systems	10 ft.	N/A	N/A

DESIGN & TECHNICAL STANDARDS

Design & Technical Standards	
<i>Soil and Site Evaluation</i>	
Who may evaluate sites:	<ul style="list-style-type: none"> ▪ Engineers & designers may do site and soil evaluation ▪ Soil scientist may only evaluate soils
Evaluation characteristics and results:	<ul style="list-style-type: none"> ▪ Number of test pits/soil logs (more may be required by DOH) - If ≥ 3 ft. vertical separation, minimum of one per 15,000 sq. ft. of proposed primary and reserve areas (minimum of 4 pits) [If < 3 ft. vertical separation, minimum of one per 10,000 sq. ft.] ▪ Location of all test pits shown on plans ▪ Sieve/hydrometer analysis needed to confirm soil type ▪ Report to include: <ul style="list-style-type: none"> ○ Water table, observation date, probable maximum height ○ Topography & drainage characteristics of proposed initial system area, reserve area, and areas immediately adjacent that may impact or be impacted by LOSS ○ Existence of structurally deficient soils ○ Location of existing site features affecting system placement ▪ Use soil/site evaluation procedures & terminology in USEPA 2002 onsite manual, except where in conflict with the rule ▪ Use soil names & particle size limits of NRCS system ▪ Note texture, structure, compaction, and other characteristics that affect treatment & water movement potential ▪ Classify soil as in following table ▪ <i>Nitrogen balance detail</i> ▪ <i>Hydrogeology report detail</i>
Soil test pits	<ul style="list-style-type: none"> ▪ Big enough and deep enough to thoroughly evaluate soil to a depth at least 3 feet below anticipated bottom of soil dispersal component ▪ Comply with chapter 296-155 WAC
DOH:	<ul style="list-style-type: none"> ▪ May require evaluation during high water season ▪ May require other soil/site information deemed necessary ▪ Will render water table decision within 12 months if typical rainfall

Soil Type Descriptions

Soil Type	Soil Textural Classifications
1	Gravelly and very gravelly coarse sands, all extremely gravelly soils excluding Soil Types 5, all soil types with greater than or equal to 90% rock fragments.
2	Coarse sands.
3	Medium sands, loamy coarse sands, loamy medium sands.
4	Fine sands, loamy fine sands, sandy loams, loams.
5	Very fine sands, loamy very fine sands; or silt loams with a moderate or strong structure (excluding platy structure)
6	Other silt loams, sandy clay loams, clay loams, silty clay loams.
7	Sandy clay, clay, silty clay, strongly cemented or firm soils, soil with a moderate or strong platy structure, any soil with a massive structure, any soil with appreciable amounts of expanding clays.

DESIGN & TECHNICAL STANDARDS

Design & Technical Standards	
<i>Design Requirements - General</i>	
Who can design?	<ul style="list-style-type: none"> ▪ Only licensed professional engineers
Design engineer to:	<ul style="list-style-type: none"> ▪ Assure all sewage from buildings directed to LOSS ▪ Assure no drainage from other drains or infiltration systems in area ▪ <i>Determine design flows for residential development based on peak daily flows:</i> <ul style="list-style-type: none"> ○ <i>120 gallons/bedroom/day (90 gal. operating capacity, 30 gal. surge capacity)</i> ○ <i>Multi-family: minimum of 240 gal./dwelling/day</i> ○ <i>Single-family or mobile home park: 360 gal./lot or space/day if they incorporate both operating and surge capacity</i> ○ <i>If different flows are used, the design flow should still incorporate both specified operating and surge capacities</i> ▪ <i>Determine design flows for non-residential development</i> <ul style="list-style-type: none"> ○ <i>Flows in following table</i> ○ <i>Flows from other sources</i> ○ <i>Comparable flows – from at least three similar establishments</i> ○ <i>Design flow should incorporate both specified operating and surge capacities</i> ▪ Estimate wastewater quality <ul style="list-style-type: none"> ○ CBOD₅, TSS, and O&G ○ Other parameters that can affect treatment processes ○ Parameters that may impact site’s sensitivity ○ Nitrogen contributions ○ Chemicals and other quality related parameters not typically found in residential wastewater ▪ For non-residential LOSS, verify it’s not industrial wastewater ▪ Assure treatment to at least typical residential septic tank effluent ▪ Provide a septic tank as the minimum level of pretreatment
<i>LOSS treatment levels</i>	<ul style="list-style-type: none"> ▪ <i>See table</i> ▪ <i>Appropriate level depends on site characteristics – See table</i> ▪ <i>Treatment level must be met prior to discharge to soil</i> ▪ <i>Bacteriological levels can be met using disinfection for Level B in type 1 soils or to meet Level C</i> ▪ <i>Coarsest texture soil in selected vertical separation determines Treatment Level for site</i>
<i>Technology “approval”</i>	<ul style="list-style-type: none"> ▪ <i>Treatment technology (except for Treatment Level N) – certified by engineer to consistently meet specified Treatment Level</i> ▪ <i>Public domain – design calculations, design standards used</i> ▪ <i>Proprietary – design calculations based on manufacturer specs, verify appropriate for specified use, quarterly sampling minimum</i> ▪ <i>Treatment Level N technology – be on DOH registered list</i> ▪ <i>Proprietary distribution technology – be on DOH registered list</i>
DOH may:	<ul style="list-style-type: none"> ▪ Require additional information/verification of treatment product ▪ Require on-going effluent sampling/service contract ▪ Not approve cesspools or seepage pits ▪ Require more stringent treatment level or design detail ▪ Deny applications where insufficient treatment history

DESIGN & TECHNICAL STANDARDS

Design flows for Facilities Other than Residential Development¹ [From: Guidance - modified]

Type of Facility	Design Unit ²	Design Flow (gpd)
Schools with showers and cafeteria	per student	16
Schools without showers and with cafeteria	per person	12.6
Schools without showers and without cafeteria	per person	10
Boarding schools	per person	75
Motels/Hotels	per room	130
Restaurants ³	per seat	50
Truckstops/Interstate restaurants ³	per seat	180
Factories/Offices (with showers)	per person per 8-hr shift	25
Factories/Offices (without showers)	per person per 8-hr shift	15
Nursing homes ³	per bed	200
Eldercare facilities/Retirement homes ³	per bed	100
Laundromats	per machine	500
Churches (without kitchen)	per seat	3
Churches (with kitchens)	per seat	5
Day Care Centers	per person	20
Picnic areas	per person	5
Campgrounds/RV parks with flush toilets only, no laundry or wet sewer hookup	per camp site	50
Campgrounds/RV parks with flush toilets, showers, laundry, no wet sewer hookup	per camp site	75
Campgrounds/RV Parks with flush toilets, showers, & wet sewer hookup, with/without laundry ³	per RV space	120
Trailer Dump Stations ³	per dump	40
Resort cabin	per person	40
Bar/Cocktail lounge ³	per seat	20

¹Primarily from "Criteria for Sewage Works Design", Department of Ecology, 98-37WQ, Revised Dec. 1998

²Does not include employees & staff, unless indicated

³Indicates potential high waste strengths facilities requiring pre-treatment

DESIGN & TECHNICAL STANDARDS

Treatment Levels

Treatment Level	Parameters				
	CBOD5	TSS	O&G	FC	TN
<i>B</i>	15 mg/L	15 mg/L	----	1,000/100 ml	----
<i>C</i>	25 mg/L	30 mg/L	----	50,000/100 ml	----
<i>E</i>	125 mg/L	80 mg/L	20 mg/L	----	----
<i>N</i>	----	----	----	----	20 mg/L

Site Conditions and Their Required Treatment Levels

Site Conditions	Required Treatment Level
<i>Soil Type 1</i>	<i>B</i>
<i>Vertical Separation of 2 to < 3 feet</i>	<i>C</i>
<i>All sites not requiring treatment levels B or C</i>	<i>E</i>
<i>An area identified where nitrogen has been identified as a contaminant of concern</i>	<i>N</i>

DESIGN & TECHNICAL STANDARDS

Design & Technical Standards	
<i>Design Requirements – Soil Dispersal Components</i>	
Soil dispersal component design requirements (except when subsurface drip is used):	<ul style="list-style-type: none"> ▪ <i>Maximum loading rate dependent on soil type – see table</i> ▪ Loading rates apply to sizing bottom of trench/bed
All SSAS meet following:	<ul style="list-style-type: none"> ▪ Vertical separation of 3 feet ▪ <i>Vertical separation of 2-3 feet if:</i> <ul style="list-style-type: none"> ○ <i>At least 2 ft. of vertical separation exist throughout proposed primary and reserve areas</i> ○ <i>Design engineer is on site during construction to verify at least 2 feet of vertical separation is maintained</i> ○ <i>DOH may impose more stringent design/management requirements</i> ○ <i>Treatment Level C or better</i> ○ <i>Hydrogeologic report verifies 2 feet is sufficient to protect</i> ▪ Infiltrative surface no more than 36 inches below final grade ▪ At least 6 inches of sidewall in original, undisturbed soil ▪ Beds can be used in soil types 1 & 2 or medium sands with maximum width of 10 ft. ▪ On slopes, laterals to be parallel with contours ▪ Cover/Backfill minimum of 6 inches, maximum of 24 inches ▪ Pressure distribution with timed dosing ▪ No reductions based on effluent quality or use of distribution technology ▪ Bottom infiltrative surface level to $\pm \frac{1}{2}$ inch ▪ When trenches used, sidewall to sidewall distance ≥ 4.5 feet. In soil type 1 or 2 or on slopes, DOH may require more ▪ When beds used, minimum distance between beds is 10 ft.
SSAS with rock and distribution pipe	<ul style="list-style-type: none"> ▪ Minimum of 2 inches rock above pipe ▪ Minimum of 6 inches rock below pipe ▪ Sidewall below invert of pipe be in original, undisturbed soil
Needed area	<ul style="list-style-type: none"> ▪ 100% primary and 100% reserve. For repair, reserve doesn't need to be identified ▪ <i>150% initially installed – 3 equally sized segments</i> <ul style="list-style-type: none"> ○ <i>Two 50% segments used at any one time, alternated annually so one segment is only in use for 1 year maximum</i> ○ <i>Separation of at least 10 ft. between edges of 50% segments</i> ▪ <i>Only 100% has to be installed when:</i> <ul style="list-style-type: none"> ○ <i>3 equal size SSAS are initially constructed</i> ○ <i>Distribution to segment must be rotated automatically</i> ○ <i>Treatment level C is provided</i>
Maximum sewage flows	<ul style="list-style-type: none"> ▪ Soil types 1 & 2 – 900 gpd/acre ▪ Soil types 3-5 – 1,570 gpd/acre

DESIGN & TECHNICAL STANDARDS

Maximum Hydraulic Loading Rate

Soil Type	Loading Rate for residential effluent (gal./sq. ft./day)
1	1.0
2	1.0
3	0.8
4	0.6
5	0.4
6	Not suitable
7	Not suitable

DESIGN & TECHNICAL STANDARDS

Design & Technical Standards	
<i>Design Requirements – Facilitate Operation, Monitoring, and Maintenance</i>	
Designed to facilitate on-going O&M	<ul style="list-style-type: none"> ▪ Service access to final grade for all system components ▪ Soil dispersal components have monitoring ports - one to the infiltrative surface ▪ Accessible controls and warning devices
Accesses	<ul style="list-style-type: none"> ▪ Designed to allow easy access, capable of being adequately secured

Design & Technical Standards	
<i>Sewage Tanks</i>	
Requirements:	<ul style="list-style-type: none"> ▪ Meet sewage tank rule requirements ▪ Prefabricated tanks on DOH sewage tank list ▪ Septic tanks: <ul style="list-style-type: none"> ○ Effluent screen on septic tank outlet ○ Effective mesh size smaller than orifice diameter in SSAS ○ Effective mesh size $\leq 1/16^{\text{th}}$ inch for subsurface drip ○ <i>Liquid volumes 200 gallons/bedroom for residential and 3 times daily operating capacity for non-residential</i> ▪ <i>Pump tanks - internal volume sufficient to provide 150 percent of the daily design flow volume above the pump's intake level</i> ▪ Grease trap – 2 times daily design flow, minimum of 1,000 gal.

Design & Technical Standards	
<i>Design, Construction, and Specification Standards</i>	
Sources of standards	<ul style="list-style-type: none"> ▪ USEPA 2002 onsite manual ▪ Ecology Criteria for Sewage Works Design ▪ LOSS guidance ▪ Other DOH guidance for different technologies

Design & Technical Standards	
<i>Collection Systems and Piping - comply with Criteria for Sewage Works Design</i>	

Design & Technical Standards	
<i>Monitoring Ports</i>	
Requirements	<ul style="list-style-type: none"> ▪ For soil dispersal component - 1 in each trench, 1 in each corner and 1 in center of bed ▪ Be a minimum of four-inches in diameter ▪ Extend from the infiltrative surface of the soil absorption component to final grade ▪ Have a cap or cover to prohibit precipitation from entering them ▪ Be anchored so they remain in place

SPECIFIC TECHNOLOGIES

SPECIFIC TECHNOLOGIES	
<i>Pressure Distribution</i>	
Orifice requirements:	<ul style="list-style-type: none"> ▪ Orifice discharge rates vary in any one lateral $\leq 10\%$ ▪ Orifice discharge rates vary over entire distribution system $\leq 15\%$ ▪ No smaller than 1/8 inches in diameter ▪ Maximum orifice spacing: <ul style="list-style-type: none"> ○ Minimum of one orifice per 6 ft² of infiltrative surface area, evenly distributed, in sand filters, sand lined trenches, recirculating gravel filters, mounds, and pressure distribution in soil types 1, 2, and 3 ○ In soil types 4 and 5, minimum of one orifice every six feet on center along the lateral
Minimum residual pressure	<ul style="list-style-type: none"> ▪ <i>≥ 2 feet with orifice diameter of 3/16 inch or larger</i> ▪ <i>≥ 5 feet with orifice diameter smaller than 3/16 inch</i>
Control panel requirements	<ul style="list-style-type: none"> ▪ Contain an elapsed time meter and a dose counter ▪ Sewage effluent rated ▪ Secure from tampering, resistant to weather (minimum of NEMA 4) ▪ Located outside within line of site of the pump tank ▪ Equipped with both audio and visual alarms ▪ Capacity for remote or off site operation and alarm notification ▪ <i><u>Capability to connect to an emergency power generator – option when smaller than required pump chamber volume is proposed</u></i>
Other requirements	<ul style="list-style-type: none"> ▪ Quick disconnect couplers or equivalent quick disconnect system for all sewage pumps ▪ Duplex alternating pumps that provide time-dosing ▪ Meet Washington State Department of Labor and Industries requirements for Class I, Division I locations ▪ Electrical control and other electrical components must be approved by Underwriters Laboratories (UL) or equivalent ▪ If float switches used, floats are mounted independent of pump discharge and transport line ▪ If any portion of the pump fittings or transport line is at a higher elevation than the drainfield, equipped with air vacuum release valve or other suitable device to avoid siphoning ▪ Minimum dose frequency shall be 6 doses per day ▪ Minimum volume of each dose at least five times the internal volume of pipe network to be pressurized ▪ Pipe materials: <ul style="list-style-type: none"> ○ Meet ASTM D2241 Class 200 or equivalent ○ For schedule 40 and schedule 80 PVC, the material must meet ASTM D1785 ▪ For pressure distribution in gravelless chambers, orifices to be oriented in 12 o'clock position ▪ Maximum spacing between outside laterals and edge of trench or bed must be 1/2 of the selected orifice spacing, ± 0.5 feet ▪ Equipped with cleanouts and monitoring ports at distal ends accessible to finished grade

SPECIFIC TECHNOLOGIES

SPECIFIC TECHNOLOGIES	
<i>Subsurface Drip System</i>	
Minimum required area	<ul style="list-style-type: none"> ▪ Dependent on daily flows, soil type, & table below
Maximum instantaneous emitter discharge rates	<ul style="list-style-type: none"> ▪ Soil types 1 & 2: 1.3 gallons/hour ▪ Soil types 3-5: 0.6 gallons/hour
Minimum # of emitters & minimum dripfield area	<ul style="list-style-type: none"> ▪ Using information in table below: <ul style="list-style-type: none"> ○ # emitters = Daily design flow ÷ maximum daily emitter discharge ○ Minimum area = # emitters X appropriate area per emitter value
Control panel requirements	<ul style="list-style-type: none"> ▪ Contain pressure gauge and meter for measuring instantaneous flow ▪ Means to track and verify dosing – e.g. event counter and elapsed time meters ▪ Sewage effluent rated ▪ Secure from tampering, resistant to weather (minimum of NEMA 4) ▪ Located outside within line of site of the pump tank ▪ Equipped with both audio and visual alarms ▪ Capacity for remote or off site operation and alarm notification ▪ Capability to connect to an emergency power generator
Other requirements:	<ul style="list-style-type: none"> ▪ Minimum install depth – 6 inches into original, undisturbed soil ▪ At least one air relief valve at high point in each distribution sector ▪ Both supply and return lines ▪ Effluent screen in septic tank filtering out solids ≤ 1/16 inch ▪ Automatic flushing of filters, manifolds, and driplines ▪ Minimum of 12 evenly spaced doses per day ▪ Quick disconnect couplers or equivalent quick disconnect system for all sewage pumps ▪ Duplex alternating pumps that provide time-dosing ▪ Meet Washington State Department of Labor and Industries requirements for Class I, Division I locations ▪ Electrical control and other electrical components must be approved by Underwriters Laboratories (UL) or equivalent ▪ If float switches used, floats are mounted independent of pump discharge and transport line ▪ Have chemical injector port ▪ Dripline: <ul style="list-style-type: none"> ○ Warranted by manufacturer for use with sewage and for resistance to root intrusion ○ Emitter discharge rate controlled by use of pressure-compensating emitters or pressure regulator ○ Be color-coded purple to identify nonpotable water

Maximum Emitter/Dripline Spacing (inches)	Minimum Area per Emitter (ft ²)	Maximum Daily Emitter Discharge (GPD/Emitter) ¹				
		Soil Types				
		1 ²	2	3	4	5
6 / 12	0.5	1.2	1.2	Not Allowed	Not Allowed	Not Allowed
12 / 12	1.0	1	1	.5	Not Allowed	Not Allowed
12 / 18	1.5	1	1	.8	.6	.4
12 / 24	2.0	1	1	.8	.8	.6
24 / 24	4.0	1	1	.8	.8	.6

SPECIFIC TECHNOLOGIES

SPECIFIC TECHNOLOGIES	
<i>Intermittent Sand Filter– can meet Treatment Level B</i>	
Required media specs:	<ul style="list-style-type: none"> ▪ Coarse sand specification <ul style="list-style-type: none"> ○ Meets particle size distribution noted in table below ○ Effective particle size < 0.3 mm ○ Uniformity coefficient < 4.0 ▪ ASTM C-33-99A
Other requirements:	<ul style="list-style-type: none"> ▪ Design engineer certifies media meets specs and provides particle size analysis results to DOH ▪ Pressure distribution with time dosing into filter ▪ Minimum doses/day: <ul style="list-style-type: none"> ○ Coarse sand: 12 ○ ASTM C-33: 6 ▪ Maximum loading rate – 1.0 gal/ft²/day ▪ Minimum media depth – 24 inches ▪ Influent quality – at least Treatment Level E ▪ Horizontal setbacks – same as for septic tank ▪ Maximum depth of cover over distribution technology in filter – 12 inches ▪ Liner: <ul style="list-style-type: none"> ○ Minimum thickness of 30 mil membrane lined by ≥ 3 inches sand, OR ○ Watertight, structurally sound concrete designed by engineer ▪ At least 2 observation ports every 1,000 sq. ft. uniformly distributed, one to top of media layer, one to bottom of filter

Required Particle Size Distribution for Coarse Sand

Sieve	Particle Diameter (in Millimeters)	Percent Passing By Weight
3/8 in	9.50	100
No. 4	4.75	95 to 100
No. 8	2.36	80 to 100
No. 16	1.18	45 to 85
No. 30	0.6	15 to 60
No. 50	0.3	3 to 15
No. 100	0.15	0 to 4

SPECIFIC TECHNOLOGIES

SPECIFIC TECHNOLOGIES	
<i>Sand Lined Trench – can meet Treatment Level B</i>	
Required media specs:	<ul style="list-style-type: none"> ▪ Coarse sand (same as for intermittent sand filter) ▪ ASTM C-33-99A
Other requirements:	<ul style="list-style-type: none"> ▪ Application limited to locations with soil type 1 ▪ Design engineer certifies media meets specs and provides particle size analysis results to DOH ▪ Minimum doses/day: <ul style="list-style-type: none"> ○ Coarse sand: 12 ○ ASTM C-33: 6 ▪ Maximum loading rate – 1.0 gal/ft²/day ▪ Minimum media depth – 24 inches ▪ Influent quality – at least Treatment Level E ▪ Horizontal setbacks measured from edge of sand, same as for SSAS ▪ At least 6 inches of media up sides of bed/trenches ▪ At least 2 observation ports every 1,000 sq. ft. uniformly distributed, one to top of media layer, one to bottom of filter

SPECIFIC TECHNOLOGIES

SPECIFIC TECHNOLOGIES	
<i>Recirculating Gravel Filter– can meet Treatment Level C</i>	
Required gravel specs:	<ul style="list-style-type: none"> ▪ Meets particle size distribution noted in table below ▪ Effective particle size between 3 and 5 mm ▪ Uniformity coefficient ≤ 2.0
Maximum influent values	<ul style="list-style-type: none"> ▪ BOD₅ – 575 mg/L ▪ O&G – 30 mg/L
Maximum loading rate (gal/ft ² /day)	<ul style="list-style-type: none"> ▪ 1150 ÷ influent BOD₅ ▪ Maximum of 5 gal/ft²/day
Other requirements:	<ul style="list-style-type: none"> ▪ Minimum media depth – 36 inches ▪ Horizontal setbacks – same as for septic tank ▪ Liner: <ul style="list-style-type: none"> ○ Minimum thickness of 30 mil membrane lined by ≥ 3 inches sand ○ Watertight, structurally sound concrete designed by engineer ▪ At least 2 observation ports every 1,000 sq. ft. uniformly distributed, one to top of media layer, one to bottom of filter ▪ Recirculating-mixing tanks sized per sewage tank rule ▪ Minimum doses per day – 48 uniformly spaced ▪ 75 – 85% of return flow from filter returned to recirculating-mixing tank

Required Particle Size Distribution for Gravel

Sieve	Particle Size (in Millimeters)	Percent Passing By Weight
3/8 inch	9.5	100
No. 4	4.75	0 to 95
No. 8	2.36	0 to 2
No. 30	0.60	0 to 0.1

SPECIFIC REQUIREMENTS

<i>SPECIFIC REQUIREMENTS</i>	
<i>Operation, Monitoring, and Maintenance – Owner Responsibilities</i>	
LOSS owner required to:	<ul style="list-style-type: none"> ▪ Meet all requirements of approved final operation and maintenance manual and current operating permit ▪ Keep daily flows below design quantity and quality ▪ Secure and maintain contracts with qualified operators ▪ Obtain and renew operating permits ▪ Provide routine maintenance and repairs when needed ▪ Use locally certified pumper for pumping tanks ▪ Protect LOSS primary and reserve area ▪ Notify DOH if failure or problems ▪ If ownership transfer: <ul style="list-style-type: none"> ▪ Notify of new owner contact information ▪ Verification that new owner has been notified of all requirements

<i>SPECIFIC REQUIREMENTS</i>	
<i>Repair of Failures</i>	
Options if LOSS failure	<ul style="list-style-type: none"> ▪ Repair or replace with conforming LOSS ▪ If that can't be done, connect facilities up to another conforming LOSS if the capacity is available or to public sewer ▪ If that can't be done, talk to Ecology about another permit for another form of discharge ▪ If that can't be done, abandon property/properties served by LOSS

<i>SPECIFIC REQUIREMENTS</i>	
<i>Expansions</i>	
If expansion proposed:	<ul style="list-style-type: none"> ▪ Must result in LOSS that meets all new system construction requirements, including requirement for reserve area

DEFINITIONS

PURPOSE AND ADMINISTRATION

<i>Definitions</i>

(1) Acronyms used in this chapter:

“**BOD₅**” means biochemical oxygen demand, typically expressed in mg/L.

“**CBOD₅**” means carbonaceous biochemical oxygen demand, typically expressed in mg/L.

“**FC**” means fecal coliform, typically expressed in number colonies/100 ml.

“**GPD**” means gallons per day.

“**LOSS**” means a large onsite sewage system.

“**O&G**” (formerly referred to as **FOG**) means oil and grease, a component of sewage typically originating from food stuffs (animal fats or vegetable oils) or consisting of compounds of alcohol or glycerol with fatty acids (soaps and lotions). Typically expressed in mg/L.

“**OSS**” means onsite sewage system.

“**PSI**” means pounds per square inch

“**SSAS**” means a subsurface soil absorption system.

“**TN**” means total nitrogen, typically expressed in mg/L

“**TSS**” means total suspended solids, a measure of all suspended solids in a liquid, typically expressed in mg/L

“**USEPA**” means United States Environmental Protection Agency

(2) Definitions used in this chapter:

“**Approved**” means a written statement of acceptability, in terms of the requirements in this chapter, issued by the department.

“**Bed**” means a soil dispersal component consisting of an excavation with a width greater than 3 feet.

“**Building Sewer**” means that part of the horizontal piping of a drainage system extending from the building drain, which collects sewage from all the drainage pipes inside a building, to an onsite sewage system. It begins two (2) feet outside the building wall and conveys sewage from the building drain to the remaining portions of the onsite sewage system. [From: 272A]

“**Cesspool**” means a pit receiving untreated sewage and allowing the liquid to seep into the surrounding soil or rock. A cesspool used by a LOSS shall be considered a failure. See Failure.

“**Conforming system**” means any large on-site sewage system meeting any of the following criteria:

- (a) In full compliance with new construction requirements under this chapter; or
- (b) Approved, installed and operating in accordance with requirements of previous editions of this chapter; or
- (c) Permitted through departmental concurrence by the waiver process which assures public health protection by higher treatment performance or other methods. [From: 272A]

“**Covenant**” means a recorded agreement stating certain activities and/or practices are required or prohibited.

PURPOSE AND ADMINISTRATION

Definitions

“Cover Material” means soil placed over a soil dispersal or treatment component composed predominately of mineral material with no greater than ten percent organic content. Cover material may contain an organic surface layer for establishing a vegetative landscape to reduce soil erosion. *[From: 272A]*

"Cuts and/or banks" means any naturally occurring or artificially formed slope greater than one hundred percent (forty-five degrees) and extending vertically at least five feet from the toe of the slope to the top of the slope as follows:

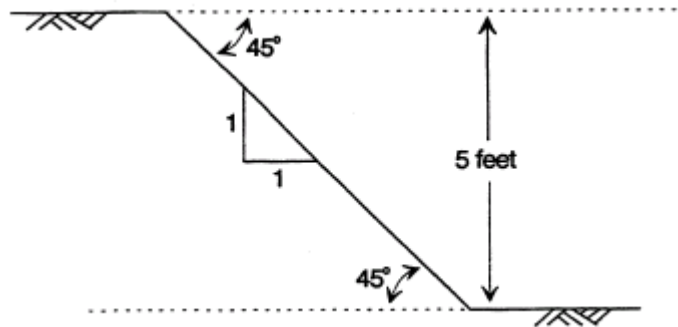

"Department" means the Washington state department of health.

"Designer" means a person who matches site and soil characteristics with appropriate on-site sewage technology. Throughout this chapter this term applies only to onsite sewage treatment system designers licensed under chapter 18.210. *[From: 272A]*

“Design Flow” means the maximum volume of sewage a residence, structure, or other facility is estimated to generate in a 24-hour period. It incorporates both an operating capacity and a surge capacity for the system during periodic heavy use events. The sizing and design of the onsite sewage system components are based on the design flow. *[From: 272A]*

“Design Engineer” means a professional engineer representing the applicant of a large onsite sewage system and responsible for developing the design and related documents for submittal to the department. See Professional Engineer.

"Development" means the creation of a residence, structure, facility, subdivision, site, area, or any activity resulting in the production of sewage. *[From: 272A]*

"Disposal component" See Soil Dispersal Component. *[From: 272A]*

“Distribution technology” means any arrangement of equipment and/or materials that distributes sewage within an onsite sewage system.

PURPOSE AND ADMINISTRATION

Definitions

“Drainrock” means clean washed gravel or crushed rock ranging in size from 3/4 inch to 2-1/2 inches, and containing no more than 2 percent by weight passing a US No. 8 sieve and no more than 1% by weight passing a US No. 200 sieve. *[From: 272A]*

“Effective particle size” (D₁₀) means the diameter of the particle in a granular sample, such as sand, for which 10 percent of the total grains are smaller and 90 percent larger on a weight basis. In other words, it is the size of a screen opening (particle diameter) where 90 percent by weight of a filter media sample is retained on the screen and ten percent passes through the screen.

"Effluent" means liquid discharged from a septic tank or other large on-site sewage system component.

"Engineer" See Professional Engineer

“Expanding clay” means a clay soil with the mineralogy of clay particles, such as those found in the Montmorillonite/Smectite Group, which causes the clay particles to expand when they absorb water, closing the soil pores, and contract when they dry out. *[From: 272A]*

"Expansion" means a change in a residence, facility, site, or use that:

- (a) Causes an on-site sewage system to exceed its existing treatment or disposal capability, for example, when a residence is increased from two to three bedrooms or a change in use from an office to a restaurant; or
- (b) Reduces the treatment or disposal capability of the existing on-site sewage system or the reserve area, for example, when a building is placed over a reserve area.

“Extremely gravelly” means soil with 60% or more, but less than 90% rock fragments by volume. *[From: 272A]*

"Failure" means a condition of a large on-site sewage system that threatens the public health by inadequately treating sewage or by creating a potential for direct or indirect contact between sewage and the public. Examples of failure include:

- (a) Sewage on the surface of the ground;
- (b) Sewage backing up into a structure caused by slow soil absorption of septic tank effluent;
- (c) Sewage leaking from a septic tank, pump chamber, holding tank, or collection system;
- (d) ~~Cesspools or~~ A seepage pits where evidence of ground water or surface water quality degradation exists;
- (e) A cesspool;
- (f) Inadequately treated effluent contaminating ground water or surface water; or
- (g) Noncompliance with standards stipulated on the permit.

“Gravelly” means soils with 15% or more, but less than 35% rock fragments by volume. *[From: 272A]*

"Ground water" means a subsurface water occupying the zone of saturated soil, permanently, seasonally, or as the result of the tides. Indications of ground water may include:

- (a) Water seeping into or standing in an open excavation from the soil surrounding the excavation.

PURPOSE AND ADMINISTRATION
<i>Definitions</i>

- (b) Spots or blotches of different color or shades of color interspersed with a dominant color in soil, commonly referred to as mottling. Mottling is a historic indication for the presence of ground water caused by intermittent periods of saturation and drying, and may be indicative of poor aeration and impeded drainage. Also see "water table."

"Holding tank sewage system" means a large on-site sewage system which incorporates a sewage tank without a discharge outlet, the services of a sewage pumper/hauler, and the off-site treatment and disposal for the sewage generated. *[From: 272A]*

"Hydraulic loading rate" means the amount of effluent applied to a given treatment step, usually expressed as gallons per square foot per day (gal/sq.ft./day). *[From: 272A]*

"Industrial wastewater" means the water or liquid-carried waste from an industrial process. These wastes may result from any process or activity of industry, manufacture, trade or business, from the development of any natural resource, or from animal operations such as feedlots, poultry houses, or dairies. The term includes contaminated storm water and leachate from solid waste facilities.

"Infiltrative Surface" means the surface within a treatment component or soil dispersal component to which effluent is applied and through which effluent moves into original, undisturbed soil or other porous treatment media. *[From: 272A]*

"Installer" means a person approved by a local health officer to install an on-site sewage systems or components who meets all of the following criteria: *[From: 272A, RDC recommendation]*

- (a) Three or more years of experience installing on-site sewage systems;
- (b) Experience must include installation of pressure distribution systems and other alternative systems;
- (c) Where a LOSS product requires proprietary or public domain treatment or distribution products, other than a septic tank followed by gravel-filled SSAS, experience must include successful completion of at least one similar installation; and
- (d) At least one letter of reference from a professional engineer, LOSS owner, government agency, or proprietary manufacturer verifying the installer has successfully completed the installation of a minimum of 5 on-site sewage systems.

"Large on-site sewage system (LOSS)" means an integrated arrangement of components for a residence, building, industrial establishment or other places not connected to a public sewer system which:

- (a) Conveys, stores, treats, discharges effluent into a soil dispersal component, and/or provides subsurface soil treatment and disposal on the property where it originates, or on adjacent or nearby property; and
- (b) Includes piping, treatment devices, other accessories, and soil underlying the disposal component of the initial and reserve areas; and
- (c) Has a design flow, at any common point, greater than three thousand five hundred gallons per day.

"Local health officer" means the health officer of the city, county, or city-county health department or district within the state of Washington, or a representative authorized by and under the direct supervision of the local health officer, as defined in chapter 70.05 RCW.

PURPOSE AND ADMINISTRATION
<i>Definitions</i>

“Maintenance” means the actions necessary to keep the onsite sewage system components functioning as designed. *[From: 272A]*

“Management Entity” means any “person” who forms and operates an onsite sewage management system for the purposes of and under the provisions of this rule, or the successors or assigns of such person. The management entity is ultimately responsible for the LOSS, including all activities necessary to assure proper and safe long-term management. *[From: RDC recommendation]*

“Massive structure” means the condition of a soil layer in which the layer appears as a coherent or solid mass not separated into peds of any kind. *[From: 272A]*

“Moderate structure” means well-formed distinct peds evident in undisturbed soil. When disturbed, soil material parts into a mixture of whole peds, broken peds, and material that is not in peds. *[From: 272A]*

“Monitoring” means periodic or continuous checking of an onsite sewage system, which is performed by observations and measurements, to determine if the system is functioning as intended and if system maintenance is needed. Monitoring also includes maintaining accurate records that document monitoring activities. *[From: 272A]*

Operator – a qualified professional who is responsible for properly monitoring and maintaining a LOSS, assuring the system he/she is responsible for meets the required treatment and dispersal performance and for preparing and submitting to the Department annual LOSS maintenance reports. *[From: RDC recommendation]*

“Operating Capacity” means the average daily volume of sewage an OSS can treat and disperse on a sustained basis. The operating capacity, which is lower than the design flow, is an integral part of the design and is used as an index in OSS monitoring. *[From: 272A]*

"Ordinary high-water mark" means the mark on lakes, streams, springs, and tidal waters, found by examining the beds and banks and ascertaining where the presence and action of waters are so common and usual, and so long continued in all ordinary years, as to mark upon the soil a character distinct from that of the abutting upland with respect to vegetation, as that condition exists on the effective date of this chapter, or as it may naturally change thereafter. The following definitions apply where the ordinary high-water mark cannot be found:

- (a) The ordinary high-water mark adjoining marine water is the elevation at mean higher high tide; and
- (b) The ordinary high-water mark adjoining freshwater is the line of mean high water. *[From: 272A]*

“Ped” means a unit of soil structure such as blocks, column, granule, plate or prism formed by natural processes. *[From: 272A]*

"Person" means any individual, corporation, company, association, society, firm, partnership, joint stock company, or any governmental agency, or the authorized agents of any such entities.

PURPOSE AND ADMINISTRATION
<i>Definitions</i>

"Planned unit development" means a subdivision characterized by a unified site design, clustered residential units and/or commercial units, and areas of common open space.

"Platy structure" means soil that contains flat pedes that lie horizontally and often overlap. This type of structure will impede the vertical movement of water. *[From: 272A]*

"Pressure distribution" means a system of small diameter pipes equally distributing effluent throughout a trench or bed, as described in the *"Recommended Standards and Guidance for Pressure Distribution Systems"* by the department. A subsurface drip system, as described in the *"Recommended Standards and Guidance for Subsurface Drip Systems"*, can be used wherever pressure distribution is required by this chapter. *[From: 272A]*

"Professional Engineer" means a person who is currently licensed as an engineer under the provisions of chapter 18.43RCW. *[From: 272A]*

"Proprietary product" means sewage treatment and distribution technologies, methods, and materials subject to a patent or trademark. *[From: 272A]*

"Public entity" means a municipal corporation, school district, port, public utility district, or state and local agencies. Municipal corporations include cities, towns, counties, water-sewer districts, public utility districts, port districts, and irrigation districts.

"Public sewer system" means a sewerage system:

- (a) Owned or operated by a city, town, municipal corporation, county, or other approved ownership consisting of a collection system and necessary trunks, pumping facilities and a means of final treatment and disposal; and
- (b) Approved by or under permit from the department of ecology, the department of health and/or a local health officer.

"Pumper" means a person approved by the local health officer to remove and transport wastewater or septage from large on-site sewage systems.

"Record drawing" means an accurate graphic and written record of the location and features of the LOSS that are needed to properly monitor, operate, and maintain that system. *[From: 272A]*

"Repair" means reconstruction or relocation, or replacement of a failed large on-site sewage system. *[From: 272A]*

"Reserve area" means an area of land approved for the installation of a conforming system and dedicated for replacement of the LOSS upon its failure.

"Restrictive layer" means a stratum impeding the vertical movement of water, air, and growth of plant roots, such as hardpan, claypan, fragipan, caliche, some compacted soils, bedrock and unstructured clay soils.

"Rock fragment" means rock or mineral fragments having a diameter of 2 millimeters or more; for example, gravel, cobbles, stones, and boulders. *[From: 272A]*

PURPOSE AND ADMINISTRATION

Definitions

"Seepage pit" means an excavation more than three feet deep where the sidewall of the excavation is designed to dispose of septic tank effluent. Seepage pits may also be called "dry wells."

"Septage" means the mixture of solid wastes, scum, sludge, and liquids pumped from within septic tanks, pump chambers, holding tanks, and other LOSS components.

"Septic tank" means a watertight pretreatment receptacle receiving the discharge of sewage from a building sewer or sewers, designed and constructed to permit separation of settleable and floating solids from the liquid, detention and anaerobic digestion of the organic matter, prior to discharge of the liquid.

"Sewage" means any urine, feces, and the water carrying human wastes, including kitchen, bath, and laundry wastes from residences, buildings, industrial establishments or other places. *[From: 272A]*

"Sewage quality" means contents in sewage that include:

- (a) CBOD₅, TSS, and O&G;
- (b) Other parameters that can adversely affect treatment. Examples include pH, temperature, and dissolved oxygen;
- (c) Other constituents that create concerns due to specific site sensitivity. Examples include fecal coliform and nitrogen. *[From: 272A]*

"Sewage tank" means a prefabricated or cast-in-place septic tank, pump tank/dosing chamber, holding tank, grease interceptor, recirculating filter tank or any other tanks as they relate to onsite sewage systems including tanks for use with proprietary products. *[From: 272A]*

"Soil dispersal component" means a technology that releases effluent from a treatment component into the soil for dispersal, final treatment and recycling. *[From: 272A]*

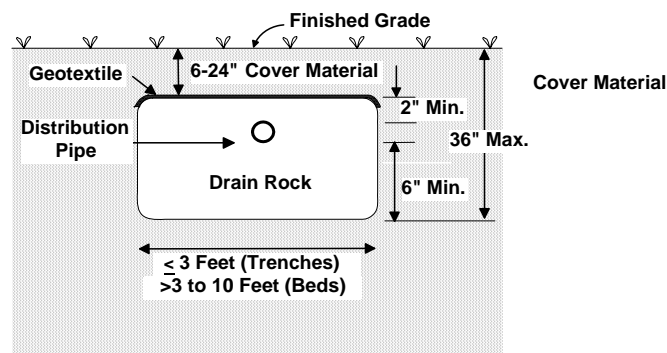

"Soil log" means a detailed description of soil characteristics providing information on the soil's capacity to act as an acceptable treatment and disposal medium for sewage.

"Soil scientist" means a person certified by the American Society of Agronomy as a Certified Professional Soil Scientist. *[From: 272A]*

PURPOSE AND ADMINISTRATION
<i>Definitions</i>

"Soil type" means a numerical classification of fine earth particles and ~~coarse~~ rock fragments as described in WAC 246-272B-11001 (2)(e). *[From: 272A]*

"Subdivision" means a division of land or creation of lots or parcels, described under chapter 58.17 RCW, now or as hereafter amended, including both long and short subdivisions, planned unit developments, and mobile home parks.

"Strong structure" means peds are distinct in undisturbed soil. They separate cleanly when soil is disturbed, and the soil material separates mainly into whole peds when removed. *[From: 272A]*

"Subsurface drip system" means an efficient pressurized wastewater distribution system that can deliver small, precise doses of effluent to soil surrounding the drip distribution piping (called dripline) as described in the department's "Recommended Standards and Guidance for Subsurface Drip Systems." *[From: 272A]*

"Subsurface soil absorption system" (SSAS) means a soil dispersal component of trenches or beds containing either a distribution pipe within a layer of drain rock covered with a geotextile, or an approved gravelless distribution technology, designed and installed in original, undisturbed, unsaturated soil providing at least minimal vertical separation as established in this chapter, with either gravity or pressure distribution of the treatment component effluent. *[From: 272A]*

"Surface water" means any body of water, whether fresh or marine, flowing or contained in natural or artificial unlined depressions for significant periods of the year, including natural and artificial lakes, ponds, springs, rivers, streams, swamps, marshes, and tidal waters.

"Timed dosing" means delivery of discrete volumes of sewage at prescribed time intervals. *[From: 272A]*

"Treatment component" means a technology that treats sewage in preparation for further treatment and/or dispersal into the soil environment. Some treatment components, such as mound systems, incorporate a soil dispersal component in lieu of separate treatment and soil dispersal components. *[From: 272A]*

"Trench" means a soil dispersal component consisting of an excavation with a width of three feet or less. *[From: 272A]*

"Uniformity coefficient" means a numeric quantity calculated by dividing the size of the sieve opening which will pass 60% of a sample by the size of the opening which will pass 10% of the sample on a weight basis. In other words it is a description of particle size distribution calculated by dividing that diameter of particle (in millimeters) of which 60 percent by weight is smaller by that diameter of particle (in millimeters) of which ten percent by weight is smaller. Symbolically this is depicted as $D_{60}/D_{10}=U_C$.

PURPOSE AND ADMINISTRATION

Definitions

"Vertical separation" means the depth of unsaturated, original, undisturbed soil of soil types 1B-5 6 between the bottom infiltrative surface of a disposal component and the highest seasonal water table, a restrictive layer, or soil types -6 or 7, as illustrated below by the profile drawing of a subsurface soil absorption system: *[From: 272A]*

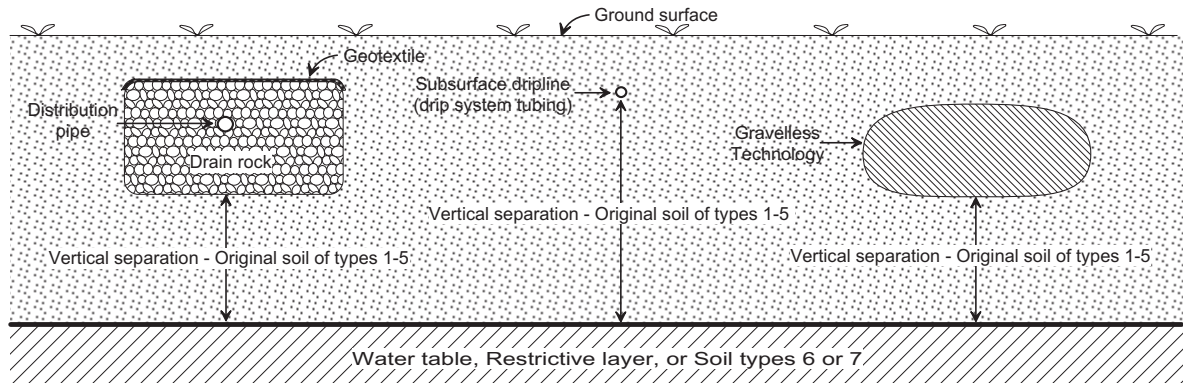

"Water table" means the upper surface of the ground water, whether permanent or seasonal. Also see "ground water."

"Well" means any excavation that is constructed when the intended use of the well is for the location, diversion, artificial recharge, observation, monitoring, dewatering or withdrawal of ground water for agricultural, municipal, industrial, domestic, or commercial use. Excluded are: 1) a temporary observation or monitoring well used to determine the depth to a water table for locating an LOSS, 2) an observation or monitoring well used to measure the effect of an LOSS on a water table, and 3) an interceptor or curtain drains constructed to lower a water table. *[From: 272A]*