

*Recommended Standards and Guidance for Performance,  
Application, Design, and Operation & Maintenance*

# **Recirculating Gravel Filter Systems**

July 2007



**This page is intentionally blank.**

*Recommended Standards and Guidance for  
Performance, Application, Design, and Operation & Maintenance*

# **Recirculating Gravel Filter Systems**

July 2007



For information or additional copies of this report contact:  
Wastewater Management Program  
Physical address: 111 Israel Road SE, Tumwater, WA 98501  
Mailing address: PO Box 47824, Olympia, WA 98504-7824

Tel: 360.236.3062  
FAX: 360.236.2257  
Webpage: <http://www.doh.wa.gov/wastewater.htm>

Mary Selecky  
Secretary of Health

For persons with disabilities, this document is available upon request in other formats.  
To submit a request, please call 1-888-586-9427 (TDD/TTY 1-800-833-6388).

Para personas discapacitadas, este documento está disponible a su pedido en otros formatos.  
Para hacer su pedido llame al 1-888-586-9427 (TDD/TTY 1-800-833-6388).

DOH Publication #337-011

**This page is intentionally blank.**

<b>Contents .....</b>	<b>Page</b>
<b>Preface.....</b>	<b>7</b>
<b>Introduction.....</b>	<b>9</b>
<b>1. Performance Standards.....</b>	<b>10</b>
1.1. Field Testing .....	10
1.2. Effluent Discharge .....	10
<b>2. Application Standards.....</b>	<b>10</b>
2.1. Listing .....	10
2.2. Permitting.....	10
<b>3. Design Standards .....</b>	<b>10</b>
3.1. Influent Characteristics .....	12
3.2. Design Flow - Daily Wastewater Flow Estimates .....	12
3.3. Pretreatment .....	12
3.4. Location Requirements .....	12
3.5. Filter Bed .....	13
3.6. Wastewater Distribution .....	14
3.7. Recirculating/Mixing Tank.....	14
3.8. Recirculating Pump.....	14
3.9. Treated Wastewater (Filtrate) Collection and Discharge .....	15
3.10. Soil Dispersal Component .....	16
<b>4. Installation Issues .....</b>	<b>17</b>
4.1. Liner Installation.....	17
4.2. Surface of the Recirculating Gravel Filter .....	17
4.3. Observation Ports.....	17
<b>5. Operation, Monitoring, and Maintenance Standards.....</b>	<b>17</b>
5.1. Management.....	17
5.2. User's Manual.....	18
5.3. Monitoring and Maintenance.....	18
5.4. Action Conditions .....	20
5.5. Appropriate Actions Upon Identification of Action conditions: .....	20
<b>Appendix A -- Filter Media Specifications .....</b>	<b>22</b>
<b>Appendix B - Containment Vessel Standards .....</b>	<b>23</b>
<b>Appendix C - Underdrains.....</b>	<b>30</b>
<b>Appendix D - Options/Comments - Flow Splitting.....</b>	<b>32</b>

**Appendix E - Inspection / Monitor Ports.....36**  
**Appendix F - Disposal of Contaminated Filter Media .....37**  
**Appendix G - Bibliography .....38**

**Figures**

Figure 1 - Typical Layout of a Recirculating Gravel Filter.....11  
Figure 2 - Typical Cross-section of a Recirculating Gravel Filter .....11  
Figure 3 - Typical Cross-section of a Recirculating /Mixing Tank.....15  
Figure 4 - Typical Cross-Section of a Recirculating Gravel Filter Underdrain .....30  
Figure 5 - Typical Cross-section of a Pumpwell .....31  
Figure 6 - Typical Cross-section of a Buoyant-ball Check Valve.....33  
Figure 1 - Splitter Basin.....34

**Tables**

Table 1 - Weight of a Cylindrical Column of Effluent.....33  
Table 2 - Buoyancy of a Sphere .....34

**Glossary of Terms..... <http://www.doh.wa.gov/ehp/ts/ww/pubs-ww-rsg.htm#glossary>**

## Preface

The recommended standards contained in this document have been developed for statewide application. Regional differences may, however, result in application of this technology in a manner different than it is presented here. In some localities, greater allowances than those described here may reasonably be granted. In other localities, allowances that are provided for in this document may be restricted. In either setting, the local health officer has full authority in the application of this technology, consistent with Chapter 246-272A WAC and local jurisdictional rules. If any provision of these recommended standards is inconsistent with local jurisdictional rules, regulations, ordinances, policies, procedures, or practices, the local standards take precedence. Application of the recommended standards presented here is at the full discretion of the local health officer.

Local jurisdictional application of these recommended standards may be:

- 1) **Adopted as part of local rules, regulations or ordinances** - When the recommended standards, either as they are written or modified to more accurately reflect local conditions, are adopted as part of the local rules, their application is governed by local rule authority.
- 2) **Referred to as technical guidance in the application of the technology** - The recommended standards, either as they are written or modified to more accurately reflect local conditions, may be used locally as technical guidance.

Application of these recommended standards may occur in a manner that combines these two approaches. How these recommended standards are applied at the local jurisdictional level remains at the discretion of the local health officer and the local board of health.

The recommended standards presented here are provided in typical rule language to assist those local jurisdictions where adoption in local rules is the preferred option. Other information and guidance is presented in text boxes with a modified font style to easily distinguish it from the recommended standards.

**Glossary of Terms:** A glossary of common terms for all RS&Gs can be found on the DOH Web site at <http://www.doh.wa.gov/ehp/ts/ww/pubs-ww-rsg.htm#glossary>.

**Typical RS&G Organization:**

<b>Standards Section</b>	<b>Explanation</b>
Performance	How this technology is expected to perform (treatment level and function)
Application	How this technology is to be applied. This section includes conditions that must be met prior to proceeding with design. Topics in this section describe the “approved” status of the technology, component listing requirements, permitting, installation, testing and inspection requirements, etc.
Design	How this technology is to be designed and constructed (includes minimum standards that must be met to obtain a permit).
Operation and Maintenance	How this technology is to be operated and maintained (includes responsibilities of various parties, recommended maintenance tasks and frequency, assurance measures, etc)
Appendices	Design examples, figures and tables, specific applications, and design and installation issues.

## **Introduction**

Recirculating gravel filters provide biodegradation or decomposition of wastewater constituents by bringing the wastewater into close contact with a well developed aerobic biological community attached to the surfaces of the filter media. The media is similar to pea gravel as specified in Appendix A. The media is contained in a watertight vessel either below the surface of the ground or wholly or partially elevated in a containment vessel. Proper function requires that influent to the filter be distributed over the media in frequent, cycled uniform doses. In order to achieve accurate dosing, these systems require a timed dosing with associated pump chambers, electrical components, and distribution network. This frequent, cycled dosing provides a constantly wetted media. The effluent is collected in the bottom of the filter and returned to the recirculating/mixing tank where it mixes with fresh septic tank effluent or a portion of the effluent is discharged to the soil dispersal component. Flow splitting mechanisms are used to control recirculation, flow splitting and discharge to the soil dispersal component. The treated wastewater is discharged to an approved soil dispersal component, usually a conventional sub-surface drainfield.

Recirculating gravel filters are quite suitable for treating residential strength wastewater. The filter will be smaller in size than an intermittent sand filter, and therefore may be preferred for this reason. The recirculating gravel filter is also not so susceptible to hydraulic and biological overloading as is an intermittent sand filter. This technology is used where size is a constraint and where wastewater strength is moderately greater than what is typically generated in a single-family residence. Recirculating gravel filter effluent may be discharged to a soil profile containing as little as 24 inches of vertical separation.

## **1. Performance Standards**

### **1.1. Field Testing**

Based on field testing and some university research results, a recirculating gravel filter, when constructed and used according to these standards and guidance, is expected to produce effluent with <10 mg/l BOD, <10 mg/l TSS and <50,000 fecal coliforms/100 ml which will meet Treatment Level C.

### **1.2. Effluent Discharge**

Effluent from a recirculating gravel filter can be discharged to vertical separations of at least 24 inches in soil types 2 through 6 and at least 60 inches in soil type 1.

## **2. Application Standards**

### **2.1. Listing**

While they are a public domain treatment technology, recirculating gravel filters are included in the Department of Health's List of Registered On-site Treatment and Distribution Products as a Category 1 treatment component (designed to treat typical residential sewage) or a Category 2 treatment component (designed to treat sewage with organic strengths higher than typical residential sewage from both residential and non-residential sources.)

### **2.2. Permitting**

Installation, and if required, operational, permits must be obtained from the appropriate local health officer prior to installation and use.

## **3. Design Standards**

Design Approval - Before construction can begin, the design must be approved by local health or other appropriate jurisdiction. All site inspections before, during, and after the construction must be accomplished by local health, other appropriate jurisdiction, or by a designer or engineer appointed by the appropriate jurisdiction.

**Figure 1 - Typical Layout of a Recirculating Gravel Filter**

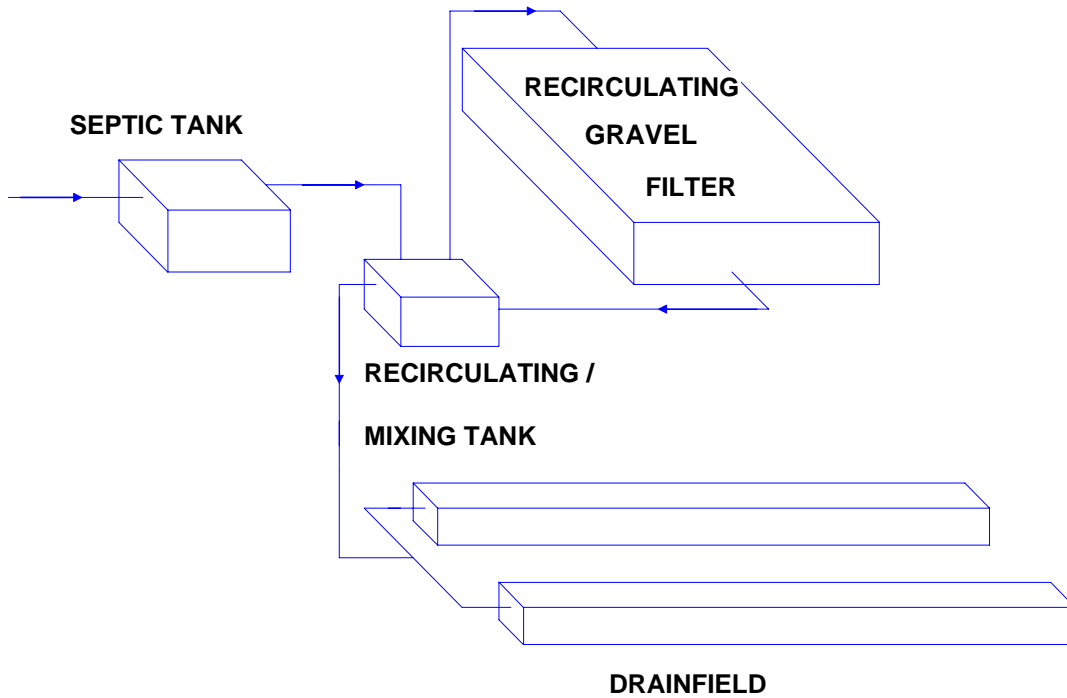

**Figure 2 - Typical Cross-section of a Recirculating Gravel Filter**

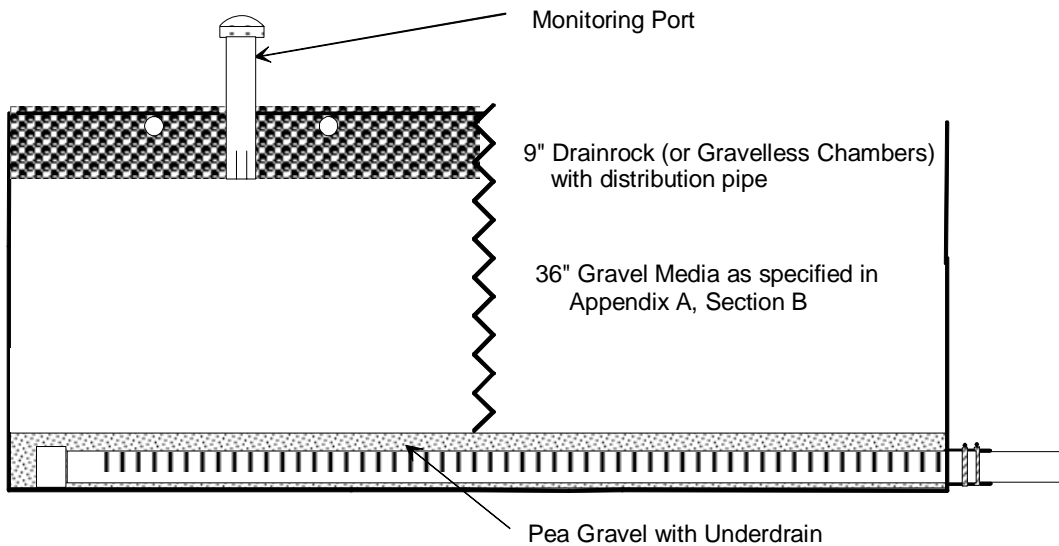

### 3.1. Influent Characteristics

- 3.1.1. Residential Wastewater: Recirculating gravel filters are quite suitable for treating residential strength wastewater. The filter will be smaller in size than an intermittent sand filter, and therefore may be preferred for this reason. The recirculating gravel filter is also not so susceptible to hydraulic and biological overloading as is an intermittent sand filter.
- 3.1.2. Non-Residential Wastewater: Recirculating gravel filters are suitable for light commercial wastewater where the BOD<sub>5</sub> does not exceed 720 mg/l.

*Recently some concerns have been expressed that recirculating gravel filters may be susceptible to premature failure, reduced treatment levels, or clogging if influent Fats, Oils & Greases are elevated or BOD<sub>5</sub> approaches 720 mg/l. While the Technical Review Committee recognizes the concerns, the committee feels that the data are inconclusive at this time. Until modifications to the standards and guidance are made, it's suggested that influent BOD<sub>5</sub> not exceed 400 mg/l and Fats, Oils and Greases not exceed 30 mg/l.*

### 3.2. Design Flow - Daily Wastewater Flow Estimates

- 3.2.1. Residential - For all residential applications, a minimum wastewater design flow of at least 120 gallons/bedroom/day must be used.
- 3.2.2. Non-Residential - For non-residential applications, a minimum wastewater design flow equal to 150% of the estimated daily flow should be used.

### 3.3. Pretreatment

- 3.3.1. If the wastewater is domestic in origin, settleable and floatable solid separation by a properly sized two-compartment septic tank with effluent baffle screening, or equivalent wastewater sedimentation/initial treatment unit, will suffice.

*Pretreatment with some other wastewater sedimentation/initial treatment unit may be used instead of a septic tank.*

- 3.3.2. If the wastewater is from a non-domestic source, pretreatment other than a septic tank may be required if the influent to the gravel filter is not within the allowable limits for recirculating gravel filters.

*Aerobic treatment or some other treatment process may be needed to modify the influent to the recirculating gravel filter to within the range of allowable limits for recirculating gravel filters.*

### 3.4. Location Requirements

The minimum setback requirements for recirculating gravel filters are the same as required for sewage tanks (WAC 262-272A-0210).

### 3.5. Filter Bed

3.5.1. Media Specifications -- Filter media must meet the particle size criteria detailed in Appendix A. Media used in constructing a recirculating gravel filter must be accompanied with a written certification from the supplier that the media fully conforms to the particle size criteria as determined by ASTM D136 and ASTM C-117.

#### 3.5.2. Filter Bed Sizing

3.5.2.1. Loading Rate: The loading rate must be calculated on the basis of the incoming BOD. Repair, alteration, and expansion projects provide the opportunity to sample and test the actual wastewater (Composite sampling is recommended). New sites must rely on wastewater strength estimates from similar facilities. The loading rate must be calculated as follows:

$$\text{Loading Rate (expressed as GPD / FT}^2\text{)} = \frac{1150}{\text{BOD}_5 \text{ of septic tank effluent}}$$

Note: The dimensionless value of 1150 in the above equation is derived from the following assumptions:

- 1 mg/L = 2.2046 x 10<sup>-6</sup> pound
- 1 gal = 3.785 L
- mass loading = 0.0096 pounds BOD<sub>5</sub>/FT<sup>2</sup>/day

For residential applications, the maximum loading rate must be 5.0 GPD/ft<sup>2</sup>. The loading rate will be less than 5.0 GPD/ft<sup>2</sup> if it is suspected that the BOD<sub>5</sub> of the particular residential wastewater is greater than 230 mg/l.

3.5.2.2. Surface area of filter bed: The surface area must be determined by dividing the design flow estimate by the loading rate.

3.5.2.3. Depth of media: The media depth must be a minimum of 36 inches.

3.5.3. Filter bed containment: The filter bed is contained either in a flexible membrane-lined pit, or a concrete vessel. Design and construction must conform to the containment standards set forth in Appendix B.

### 3.6. Wastewater Distribution

- 3.6.1. Pressure distribution: Pressure distribution with timed dosing is required and must comply with the pressure distribution standards and guidance. This requirement applies to all pressure distribution related components.
- 3.6.2. Wastewater application to the filter bed: The wastewater must be applied to the layer of drain rock atop the filter media, or sprayed upward against the top of gravelless chambers.

*Recirculating gravel filter media may be utilized in lieu of drainrock in the top of the filter bed.*

### 3.7. Recirculating/Mixing Tank

The volume of the recirculating/mixing tank is determined by the following:

- 3.7.1. For residential systems: 150% of the daily wastewater flow estimate.
- 3.7.2. For non-residential systems: 100% of the daily wastewater flow estimate.

### 3.8. Recirculating Pump

- 3.8.1. Controls - The recirculating pump must be controlled by a timer with a dosing schedule that provides for frequent, cycled uniform doses, allowing the influent/filtrate mixture to cycle through the filter about 5 times before discharge.

*Optimum pumping cycles are for one continuous cycle every 30 minutes (48 cycles per day) with the off cycle set for approximately 25 minutes. The on cycle should be set so that the orifice discharge per dose cycle does not exceed 2 gallons per orifice.*

*Float switches are wired in parallel with the timer to control the pump during periods of excessive wastewater flows, and in event of timer malfunction. (See Figure 3) Both timer and float switch controls are required. To protect the pump and the distribution pipe network orifices, the outlet of the septic tank must include screening of the effluent unless screening of the pump is provided. (See standards and guidance for pressure distribution systems for effluent screening.)*

*In the event of low levels in the recirculating/mixing tank, to protect the pump by assuring adequate pump submergence, a redundant off/low level alarm control float is recommended. The redundant off/low level alarm shall be installed in accordance with the pump manufacturer's recommendations to assure adequate pump submergence.*

**Figure 3 - Typical Cross-section of a Recirculating/Mixing Tank with a Buoyant Ball Check Valve**

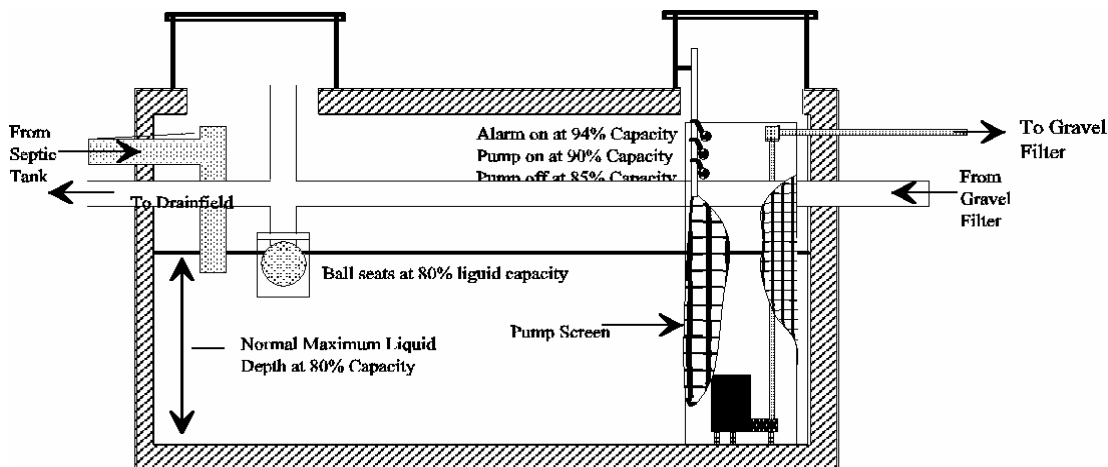

*Pump screen optional - see Section 3.8.*

*Additionally, in the event of low levels in the recirculating/mixing tank, to protect the pump by assuring adequate pump submergence a redundant off/low level alarm switch is recommended in addition to the switches indicated in the above figure - see Section 3.8.*

3.8.2. Flow rate for recirculating pump: The minimum recirculating pump flows, in gallons per minute, can be calculated by the following formulas.

$$\text{Daily Design Flow (GPD)} \times 5 = \text{Through - filter flow (GPD)}$$

$$\frac{\text{Through - filter flow (GPD)}}{\text{pump cycles per day}} = \text{Gallons per cycle}$$

$$\frac{\text{Gallons per cycle}}{\text{minutes per on cycle}} = \text{Gallons per minute}$$

\*It should be noted that the pressure distribution network design in the recirculating gravel filter may result in a higher discharge rate.

### 3.9. Treated Wastewater (Filtrate) Collection and Discharge

Filtrate may be collected and discharged from the bottom of the gravel filter by either a gravity-flow underdrain, or a pumped-flow pumpwell system. When gravel filters are

membrane-lined, gravity flow underdrains must exit through a boot. The boot and exit pipe must be installed and tested according to the standards in Appendix C.

- 3.9.1. Filter to recirculating/mixing tank pipe sizing: The pipe from the filter to the mixing/recirculation tank can be sized using the Hazen-Williams equation, which relates flow, pipe diameter, slope, and pipe smoothness. Typically it is expressed in the following manner:

$$S = \left[ \frac{2.31 \times Q}{Ch \times d^{2.63}} \right]^{1.852}$$

Where:

S = Slope of the energy gradient, in feet

Q = flow, in cubic feet per second

Ch = dimensionless smoothness coefficient (typical value of 150 for PVC pipe)

d = inside diameter of pipe, in feet

Rearranging this equation and multiplying by 12, provides an equation to calculate the appropriate pipe diameter, in inches, for gravity flow underdrain pipe and filter-to-recirculating tank transport pipe. It is also the size (inlet and outlet diameters) of the buoyant-ball check valve (where applicable).

$$d = 12 \left[ \frac{2.31 \times Q}{Ch \times S^{.54}} \right]^{.38}$$

- 3.9.2. Recirculation Flow Splitting Mechanisms: Wastewater which has been treated in the recirculating gravel filter, collects at the bottom of the filter through an underdrain and a portion is returned to the recirculating/mixing tank. The return flow must be split to direct a minimum of 75-85% of the treated wastewater back to the recirculating/mixing tank and the remainder to the soil dispersal component. A recirculation rate of at least 5:1 must be maintained. Options and comments concerning flow splitting are noted in Appendix D.

*To encourage mixing of fresh influent with partially treated recirculating return filtrate, the return line from the filter should enter the recirculating/mixing tank at the same end of the tank as the influent from the septic tank and at the opposite end from the recirculating pump.*

### 3.10. Soil Dispersal Component

- 3.10.1. Discharge of effluent from an intermittent sand filter to a soil dispersal component (subsurface soil absorption) is required. Direct discharge of effluent from a recirculating gravel filter to surface water or upon the ground surface is prohibited by WAC 246-272A-0230(2)(a).

- 3.10.2. WAC 246-272A provides for SSAS design allowances, which vary according to treatment performance levels.
- 3.10.3. The size and design of the soil dispersal component must be consistent with the methods and procedures indicated by WAC 246-272A-0200, WAC 246-272A-0220, WAC 246-272A-0230, and WAC 246-272A-0234.
- 3.10.4. The soil dispersal component location must meet minimum horizontal setback distances as specified by WAC 246-272A-0210 and 246-272A-0280.
- 3.10.5. Development using a recirculating gravel filter must meet the minimum land area requirements specified in WAC 246-272A-0320.

#### **4. Installation Issues**

##### **4.1. Liner Installation**

If the containment vessel is constructed of a 30 mil PVC liner, the liner must be protected by a 3 inch layer of sand beneath the liner.

##### **4.2. Surface of the Recirculating Gravel Filter**

The surface of the recirculating gravel filter differs from the intermittent sand filter, sand-lined trenches and stratified sand filters in that the surface must remain “open” to encourage oxygenation of the filter. No cover soil is to be placed above the upper layer of drainrock in the recirculating gravel filter.

##### **4.3. Observation Ports**

If the recirculating gravel filter effluent exits the gravel filter through the underdrain by gravity flow, two observation ports must be installed in the gravel filter. One observation port must be installed to the bottom of the drainrock/top of the media interface. A second observation port must be installed to the bottom of the underdrain. If the effluent exits the gravel filter through a pumpwell, the pumpwell may be used as the second observation port.

#### **5. Operation, Monitoring, and Maintenance Standards**

##### **5.1. Management**

The local health officer has the authority to require that an acceptable maintenance agreement be established, and supporting documents be developed and approved by the local health officer, prior to the issuance of approvals for a proposed recirculating gravel filter sewage system. It is recommended that a maintenance agreement be required when, in the opinion of the local health authority, the ongoing operation of the gravel filter sewage systems is best assured by the existence of such an agreement.

## **5.2. User's Manual**

A user's manual for the system must be developed and / or provided by the system designer at the time the system installation "as-built" drawing is completed. These materials must contain the following, at a minimum:

- 5.2.1. diagrams of the system components;
- 5.2.2. explanation of general system function, operational expectations, owner responsibility, etc.;
- 5.2.3. names and telephone numbers of the system designer, local health authority, component manufacturer, supplier/installer, and/or the management entity to be contacted in the event of a failure;
- 5.2.4. information on the periodic monitoring and maintenance requirements of the sewage system: septic tank, dosing and recirculating/mixing tanks, filter unit, pumps, switches, alarms, disposal unit, etc.;
- 5.2.5. information on "Trouble-shooting" common operational problems that might occur. This information should be as detailed and complete as needed to assist the system owner to make accurate decisions about when and how to attempt corrections of operational problems, and when to call for professional assistance; and
- 5.2.6. for proprietary recirculating gravel filter devices, a complete maintenance and operation document must be developed and provided by the manufacturer. This document must be made available, through the system designer, to the system owner. This document must include all the appropriate items mentioned above, plus any additional general and site-specific information useful to the system owner, and/or the maintenance person. A copy of this document must also be provided to the local health authority, prior to the issuance of the local installation permit.

## **5.3. Monitoring and Maintenance**

- 5.3.1. Responsibility - For the on-site sewage system to operate properly, its various components need periodic monitoring and maintenance. Monitoring and maintenance are the responsibility of the homeowner, but may be best performed by experienced and qualified service providers. An Operation and Maintenance Manual must be developed and/or provided by the system designer with copies provided to the local health officer, system owner, and maintenance contractor. The maintenance manual must include the following listed recommended maintenance descriptions and schedules. The local health officer may specify additional requirements.

### 5.3.2. Minimum Monitoring and Maintenance Description and Service Items

- 5.3.2.1. Type of use.
- 5.3.2.2. Age of system.
- 5.3.2.3. Specifications of all electrical and mechanical components installed (occasionally components other than those specified on the plans are used).
- 5.3.2.4. Nuisance factors, such as odors or user complaints.
- 5.3.2.5. Septic tank: inspect yearly for structural integrity, proper baffling, screen, ground water intrusion, and proper sizing. Inspect and clean effluent baffle screen and also pump tank as needed.
- 5.3.2.6. Dosing and Recirculating/Mixing Tanks: clean the effluent screen (spraying with a hose is a common cleaning method), inspect and clean the pump switches and floats yearly. Pump the accumulated sludge from the bottom of the chambers, whenever the septic tank is pumped, or more often if necessary.
- 5.3.2.7. Pumpwell: Inspect for infiltration, structural problems and improper sizing. Check for pump or siphon malfunctions, including problems related to dosing volume, pressurization, breakdown, clogging, burnout, or cycling. Pump the accumulated sludge from the bottom of the pumpwell, whenever the septic tank is pumped, or whenever necessary.

*The liquid level at the pump start or siphon must be below the bottom of the filter media in order to prevent ponding and rise of the capillary fringe in the gravel media. Improper liquid level (too high in the pumpwell) can result from improper setting of the pump on float, pump burnout, disconnected electrical supply to the pump or controls, or tripped circuit breaker. In some cases the underdrain may be underdesigned and may not have the flow capacity to supply the pump at the rate that it pumps. Infiltration into the pumpwell is serious and means that the effluent is entering the pumpwell before passing through the full column of media filter. Effluent that is short circuiting will not receive full filter treatment.*

- 5.3.2.8. Check monitoring ports for ponding. Conditions in the observation ports must be observed and recorded by the service provider during all operation and maintenance activities for the recirculating gravel filter and other system components. For reduced sized drainfields, these observations must be reported to the local health jurisdiction responsible for permitting the system.

- 5.3.2.9. Inspect and test yearly for malfunction of electrical equipment such as timers, counters, control boxes, pump switches, floats, alarm system or other electrical components, and repair as needed. System checks should include improper setting or failure, of electrical, mechanical, or manual switches.
- 5.3.2.10. Mechanical malfunctions (other than those affecting sewage pumps) including problems with valves, or other mechanical or plumbing components.
- 5.3.2.11. Malfunction of electrical equipment (other than pump switches) such as timers, counters, control boxes, or other electrical components.
- 5.3.2.12. Material fatigue, failure, corrosion problems, or use of improper materials, as related to construction or structural design.
- 5.3.2.13. Neglect or improper use, such as loading beyond the design rate, poor maintenance, or excessive weed growth.
- 5.3.2.14. Installation problems, such as improper location or failure to follow design.
- 5.3.2.15. Overflow or backup problems where sewage is involved.
- 5.3.2.16. Recirculating Gravel Filter / exposed-surface filter bed: weed and remove debris from the bed surface, quarterly.
- 5.3.2.17. Specific chemical/biological indicators, such as BOD, TSS, fecal or total coliforms, etc. Sampling and testing may be required by the local Health Officer on a case-by-case basis, depending on the nature of the problem, availability of laboratories, or other factors.
- 5.3.2.18. Information on the safe disposal of discarded filter media. See Appendix E.

#### **5.4. Action Conditions**

When a monitoring inspection, or any other observation, reveals either of the following listed conditions, the owner of the system must take appropriate action, according to the direction and satisfaction of the local health officer:

- 5.4.1. Drainfield system failure, as defined in WAC 246-272A-0010, or
- 5.4.2. A history of long-term, continuous and increasing ponding of wastewater within the reduced-size drainfield, which if left unaddressed, will probably result in untimely failure.

#### **5.5. Appropriate Actions Upon Identification of Action conditions:**

- 5.5.1. repair or modification of the drainfield system,
- 5.5.2. expansion of the drainfield system, or
- 5.5.3. modifications or changes within the structure relative to wastewater strength or hydraulic flows

*The repair or modification required may include the installation of additional drainfield to enlarge the system to 100% of the initial design size. Repair or modification is not limited to this option. Local permits must be obtained before construction begins, according to local health department requirements. Any repair or modification activity must be reported as part of the monitoring activity for the site.*

**Appendix A -- Filter Media Specifications**

**I** Particle Size Analysis - The standard method to be used for performing particle size analysis must comply with one of the following:

- A.** The sieve method specified in ASTM D136 and ASTM C-117
- B.** The method specified in Soil Survey Laboratory Methods and Procedures for Collecting Soil Samples, Soil Survey Investigation Report #1, US Department of Agriculture, 1984.

Information concerning these methods can also be obtained from Methods of Soil Analysis, Part I, 2nd edition; A. Klute, editor, ASA Monograph #9, American Society of Agronomy, Madison, WI, 1986.

**II** Recirculating Gravel Filter Media - All four conditions must be met to satisfy media criteria.

**A.** Particle Size Distribution:

<u>Sieve</u>	<u>Particle Size</u>	<u>Percent Passing</u>
3/8 inch	9.50 mm	100
No. 4	4.75 mm	0 to 95
No. 8	2.36 mm	0 to 2%
No. 30	0.60 mm	0 to 0.1%

- B.** Effective Size: 3 mm to 5 mm.
- C.** Uniformity coefficient: less than or equal to 2.
- D.** Filter media must be washed.

**Appendix B - Containment Vessel Standards**

**I Lined Pit** - when a sand filter is constructed in an excavated pit the following criteria are to be met. (Note: The majority of the following liner specification is from the State of Oregon On-Site Sewage Disposal Rules.)

**A. Polyvinyl chloride (PVC)** shall have the following properties:

PROPERTY	TEST METHOD	
(a) Thickness	ASTM D1593 Para 9.1.3	30 mil minimum
(b) Specific Gravity (Minimum)	ASTM D792 Method A	
(c) Minimum Tensile Properties (each direction)	ASTM D882	
(A) Breaking Factor (pounds/inch width)	Method A or B (1 inch wide)	69
(B) Elongation at Break (percent)	Method A or B	300
(C) Modulus (force) at 100% Elongation (pounds/inch width)	Method A or B	27
(d) Tear Resistance (pounds, minimum)	ASTM D1004 Die C	8
(e) Low Temperature	ASTM D1790	-20°F
(f) Dimensional Stability (each direction, percent change maximum)	ASTM D1204 212°F, 15 min.	± 5
(g) Water Extraction	ASTM D1239	-0.35% max.
(h) Volatile Loss	ASTM D1203 Method A	0.7% max.
(I) Resistance to Soil Burial (percent change maximum in original value)	ASTM D3083	
(A) Breaking Factor		-5
(B) Elongation at Break		-20
(C) Modulus at 100% Elongation		±10
(j) Bonded Seam Strength (factory seam, breaking factor, ppi width)	ASTM D3083	55.2
(k) Hydrostatic Resistance	ASTM D751 Method A	82

## **B. Installation Standards**

1. Patches, repairs and seams shall have the same physical properties as the parent material;
2. Site considerations and preparation:
  - a. The supporting surface slopes and foundation to accept the liner shall be stable and structurally sound including appropriate compaction. Particular attention shall be paid to the potential of sink hole development and differential settlement;
  - b. Soil stabilizers such as cementations or chemical binding agents shall not adversely affect the membrane; cementations and chemical binding agents may be potentially abrasive agents.
3. To avoid deterioration of the membrane liner caused by exposure to weather or sunlight, the liner must be protected by being fully buried. In cases where portions of the liner may be subject to direct exposure to the weather (for example in a recirculating gravel filter system in which the top edges of the liner may not be buried due to the system design requirements), the exposed portions of the liner must be covered. (An example might be to construct a finish rim over the exposed liner portions.)
4. Non-reinforced liners have high elongation and can conform to irregular surfaces and follow settlements within limits. Unreasonable strain reduces thickness and may reduce life expectancy by lessening the chemical resistance of the thinner (stretched) material. Every effort shall be made to minimize the strain (or elongation) anywhere in the flexible membrane liner;
5. Construction and installation:
  - a. Bottom of pit
    - (1) Cover with sand to "bed" liner, adequate in depth (minimum 3") to protect liner from puncture, or
    - (2) Use a non-woven needle-punched synthetic geotextile fabric, in a thickness appropriate to the tasks of protecting the liner.
    - (3) Regardless of whether sand or a fabric is used, grade the bottom to provide a sloping liner surface, from the outer edge of the filter toward the point of underdrain collection. Slope equal to 8 inches fall overall or one inch of fall per foot of run, whichever is the greatest.
  - b. Sides of the pit - smooth, free of possible puncture points.

- c. Climatic conditions:
- (1) Temperature. The desirable temperature range for membrane installation is 42° F to 78° F. Lower or higher temperatures may have an adverse effect on transportation, storage, field handling and placement, seaming and backfilling and attaching boots and patches may be difficult. Placing liner outside the desirable temperature range shall be avoided;
  - (2) Wind. Wind may have an adverse effect on liner installation such as interfering with liner placement. Mechanical damage may result. Cleanliness of areas for boot connection and patching may not be possible. Alignment of seams and cleanliness may not be possible. Placing the liner in high wind shall be avoided;
  - (3) Precipitation. When field seaming is adversely affected by moisture, portable protective structures and/or other methods shall be used to maintain a dry sealing surface. Proper surface preparation for bonding boots and patches may not be possible. Seaming, patching and attaching 'boots' shall be done under dry conditions.
- d. Boots: When boots are used (required when using a gravity-flow underdrain), the boot and exit pipe must be installed with the following criteria:
- (1) The system designer is to identify the use of a sand filter liner with underdrain and boot as a part of the application for on-site sewage system and provide specifications detailing design and installation requirements.
  - (2) The boot is to be installed by the manufacturer or the manufacturer's representative.
  - (3) The boot outlet is to be bedded in sand.
  - (4) The boot is to be sized to accommodate an underdrain outlet pipe.
  - (5) The boot is to be secured to the underdrain outlet pipe with two (2) stainless steel bands and screws, and sealant strips as recommended by the manufacturer.
  - (6) The underdrain is to be designed in accordance with Appendix C, Underdrains and exit the side of the liner.
  - (7) An inspection port must be installed in the sewer pipe from the filter to the drainfield.

- (8) Gravity sewer pipe from the filter to the drainfield must be ASTM 3034 ring tight.
  - (9) When site conditions are such that the trench from the sand filter to the drainfield may act as a conduit for ground water movement towards the drainfield (for example on sites with shallow groundwater of poorly drained sites), the trench must be back-filled with a minimum 5 lineal feet clay mix (or bentonite mix) dam.
  - (10) If the boot may be submerged in a seasonal high water table, performance testing of the sand filter/boot for leakage must be conducted in the following manner:
    - (a) Block outlet pipe;
    - (b) Fill underdrain gravel with water;
    - (c) Measure and record elevation of water through observation/inspection port;
    - (d) Let stand 24 hours minimum;
    - (e) Measure and record elevation of water through observation/inspection port;
    - (f) No allowable drop in the water level.
- e. Liner Placement:
- (1) Size. The final cut size of the liner shall be carefully determined and ordered to generously fit the container geometry without field seaming or excess straining of the linear material;
  - (2) Transportation, handling and storage. Transportation, handling and storage procedures shall be planned to prevent material damage. Material shall be stored in a secured area and protected from adverse weather;
  - (3) Site inspection. A site inspection shall be carried out by local health officer, other appropriate jurisdiction or by a designer or engineer appointed by the appropriate jurisdiction, and the installer prior to liner installation to verify surface conditions, etc.;
  - (4) Deployment. Panels shall be positioned to minimize handling. Seaming should not be necessary. Bridging or stressed conditions shall be avoided with proper slack allowances for shrinkage. The liner shall be secured to prevent movement and promptly backfilled;

- (5) Anchoring trenches. The liner edges should be secured frequently in a backfilled trench;
- (6) Field seaming. Field seaming, if absolutely necessary, shall only be attempted when weather conditions are favorable. The contact surfaces of the materials should be clean of dirt, dust, moisture, or other foreign materials. The contact surfaces shall be aligned with sufficient overlap and bonded in accordance with the suppliers recommended procedures. Wrinkles shall be smoothed out and seams should be inspected by non-destructive testing techniques to verify their integrity. As seaming occurs during installation, the field seams shall be inspected continuously and any faulty area repaired immediately;
- (7) Field repairs. It is important that traffic on the lined area be minimized. Any necessary repairs to the liner shall be patched using the same lining material and following the recommended procedure of the supplier;
- (8) Final inspection and acceptance. Completed liner installations shall be visually checked for punctures, rips, tears and seam discontinuities before placement of any backfill. At this time the installer shall also manually check all factory and field seams with an appropriate tool. In lieu of or in addition to manual checking of seams by the installer, either of the following tests may be performed;
- (9) Wet Test: The lined basin shall be flooded to the one (1) foot level with water after inlets and outlets have been plugged. There shall not be any loss of water in a 24 hour test period.
- (10) Air Lance Test: Check all bonded seams using a minimum 50 PSI (gauge) air supply directed through a 3/16 inch (typical) nozzle held not more than 2 inches from the seam edge and directed at the seam edge. Riffles indicate unbonded areas within the seam, or other undesirable seam construction.

**II Lined Framework** - A perimeter support frame to hold the liner in place during construction may be used. Framework shall be straight, free from warps or bends. Framework shall be of sufficient rigidity so that springing will not occur under the weight of the media and/or backfill placement. Framework shall be sufficiently supported to prevent excessive deflection of the framework.

*Plywood with 2x4 framing support (or minimum 2' centers) is a suggested method. Treated wood should be used to prevent deterioration of the wood by termites, decomposition, etc.*

#### **A. Media and liner placement**

1. It is important that sand is placed between the framework and excavated soil simultaneously with placement of the treatment media. This keeps the framework and liner vertical during the course of construction and results in a sand cushion around the outside perimeter of the lined framework. All nails or staples used must have their sharp ends pointed away from the liner. The PVC liner is unfolded from the center of the excavation and draped over the top edges of the perimeter support frame. Care should be taken to prevent contact between the liner and the sharp edges of the top of the perimeter support frame.

*A garden hose which has been cut longitudinally and placed on the top edge of the support frame would be a suggested method.*

2. Care must be taken to ensure that the liner is in full contact with the bottom and sides and that no bridging occurs.

*Pleats or wrinkles in the liner should be minimized. Pleats and wrinkles in the liner may allow for a tunneling effect of effluent through the pleat or wrinkle.*

- B. Backfill around framework:** If site conditions are such that a partially elevated filter is desired or necessary, backfill around the sides of the filter shall be non-clay material containing no pieces more than 3 inches across, any frozen lumps, and any wood or other foreign material. The backfill material around the sides of the filter shall be placed in layers no more than 2 feet thick (loose), with each layer tamped and graded so that final settling will provide for side slopes on the sides of the filter backfill to be approximately 3:1 from the top of the filter, to native ground.

### III Concrete Containment Vessel

- A. Above ground tank** - to be designed and/or approved by a qualified professional engineer if the following conditions are not met.

1. Walls
  - a. at least 6 inches thick
  - b. Above ground height is 4 feet or less
  - c. rebar reinforcement: 3/8 inch diameter rebar on 2-foot centers horizontally and vertically, with continuous lengths wrapped around the corners.

2. Floor

- a. at least 3 1/2 inches thick
  - b. reinforced with steel mesh (CRSI standard #6-1010) to prevent cracking and to maintain water-tightness
3. Tank is to be designed, constructed, and sealed to be water-tight

**B.** Below ground tank

Any below-ground concrete tank must be water-tight. The design of any such tank is to be approved by a qualified professional engineer and, where required by local and/or state regulation, the local health officer.

## Appendix C - Underdrains

For Concrete Tanks or Synthetic Membrane-Lined Pits: Either gravity underdrains or pumpwells may be used.

Underdrains: Underdrains must be designed with sufficient void storage volume to provide for a single drainfield dose with reserve capacity to maintain unsaturated filter media above the underdrain system. Collection pipe must be sized of sufficient size, with adequate perforations, or slots so that filtrate can flow from the void storage space into the collection pipe rapidly enough to maintain unsaturated filter media above the underdrain system. However, the minimum size of the collection pipe shall be 4" diameter. Underdrains may be designed in a variety of ways.

One possible way is:

*Place a 3 inch layer of pea gravel over a 6 inch layer of 3/4 to 2-1/2 inch gravel containing the underdrain collection pipe. The purpose of the pea gravel is to restrict the migration of sand into the gravel and pipe in the underdrain. The gravel surrounding the slotted or perforated pipe should be sized larger than the slots or perforations to prevent migration of gravel into the pipe. See figure below. For the purpose of calculating void storage space in the medium gravel (3/4 to 2-1/2 inch), 3.0 gallons per cubic foot may be used assuming 40% void space per cubic foot.*

**Figure 4 - Typical Cross-section of a Recirculating Gravel Filter Underdrain**

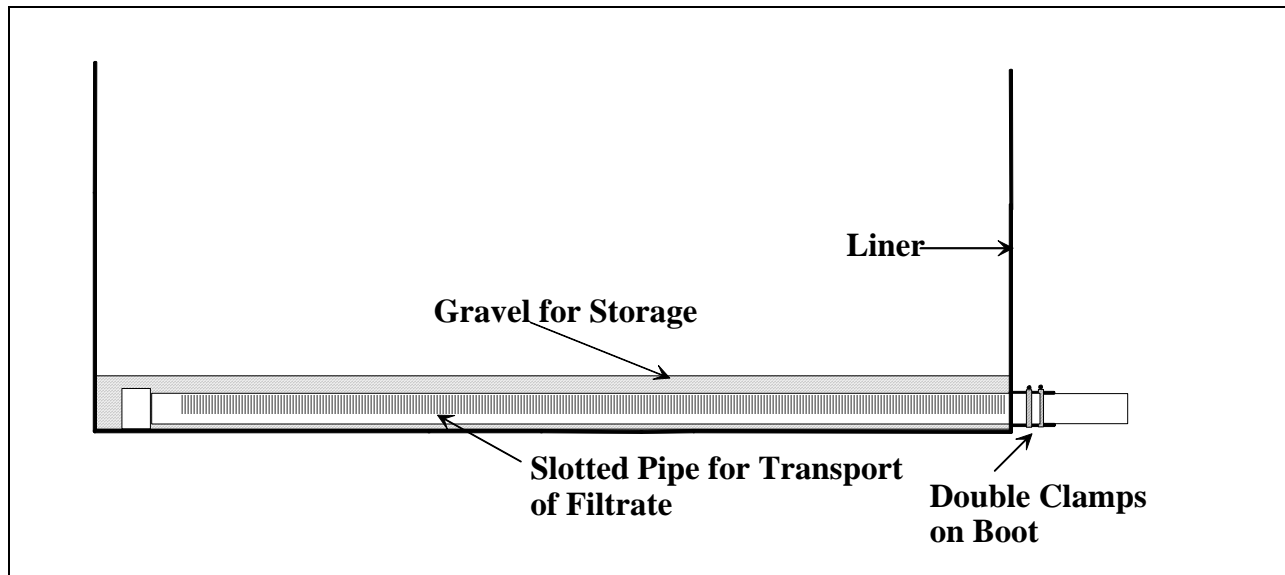

Pumpwells: are located within the filter. Filtrate is collected in an underdrain system underlying the filter media and is discharged directly into the pumpwell.

Pumpwells may be designed a variety of ways, but they must be constructed of concrete or plastic sewer pipe. A sufficient number and size of holes must exist in the pumpwell, at the level of the underdrain system, so that filtrate can flow into the pumpwell, from the underdrain void space, as rapidly as the filtrate is pumped out of the pumpwell. The pumpwell must be adequately supported on both sides of the synthetic membrane.

**Figure 5 - Typical Cross-section of a Pumpwell in a Synthetic Membrane-lined Recirculating Gravel Filter**

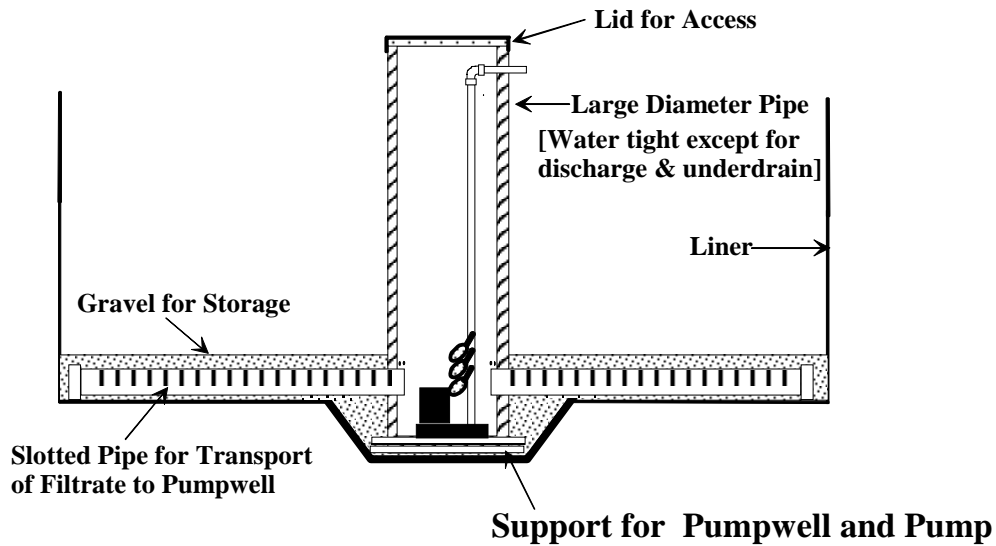

## Appendix D - Options/Comments - Flow Splitting

Splitting the return flow from the recirculating gravel filter to direct a minimum of 75-85% of the treated wastewater back to the recirculating/mixing tank and the remainder to the soil dispersal component can be accomplished in a variety of ways. Following are two customary and/or suggested splitting methods and a potential option that does not incorporate flow splitting:

### Option 1. Buoyant-Ball Check Valve: (Recirculating Ball Valve) (See Figure 4)

**Description:** The buoyant-ball check valve typically consists of

- (1) an inlet from the filter,
- (2) an outlet to the drainfield,
- (3) an outlet downward (into the mixing chamber),
- (4) a buoyant ball which seals the downward outlet,
- (5) a basket which retains the ball below the downward outlet, and
- (6) an observation port

**Operation:** During periods of low flow, all return flow from the recirculating gravel filter is returned to the recirculating/mixing tank through the ball valve. As the level of the liquid in the recirculating/mixing tank rises, the ball exerts enough force to make a firm seal. The upward force that the ball exerts needs to be sufficient to maintain a complete seal even with the return line (from the sand filter) completely full. When the ball seals the downward outlet, filtrate is discharged to the drainfield. This discharge continues until the level in the tank drops enough to unseat the ball in the valve. For systems with a high velocity of effluent in the return pipe (filter to mixing tank), the ball valve assembly may need to be equipped with a baffle to “slow” the effluent down as it enters the recirculating/mixing tank to help prevent bypassing the downward outlet.

*There are commercially available recirculating ball valves. Design and selection of a commercially available valve assembly must be in accordance with the manufacturer's recommendations.*

**Figure 6 - Typical Cross-section of a Buoyant-ball Check Valve**

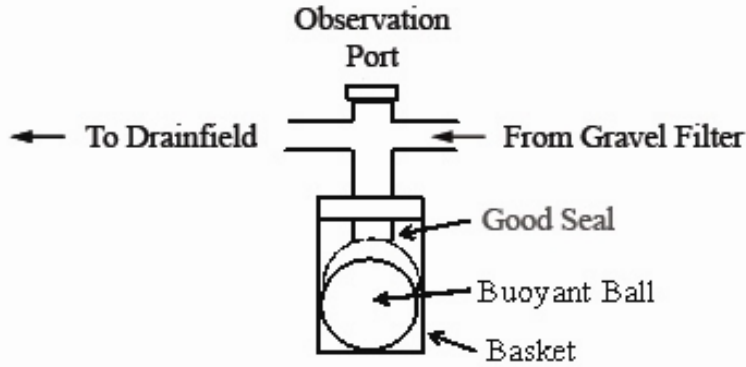

Tables 1 & 2 are provided as a guide in designing a buoyant-ball check valve. Actual inside diameters of the pipe and actual outside diameters of the ball must be used. The weight of the column of liquid is shown in Table 1. Table 2 provides the buoyancy of a sphere. The weight of the column of liquid in the return pipe must be overcome by the buoyant force of the ball. (Note: the weight of the sphere is neglected.) Density of effluent is assumed to be approximately 62.4 pounds/ft<sup>3</sup>

<b>Table 1 - Weight of a Cylindrical Column of Effluent</b>									
Diameter, Inches	2	3	4	5	6	7	8	10	12
Length, Inches	Weight of a cylindrical column of effluent, in pounds								
4	0.5	1.0	1.8	2.8	4.1	5.6	7.3	11.3	16.3
5	0.6	1.3	2.3	3.5	5.1	6.9	9.1	14.2	20.4
6	0.7	1.5	2.7	4.3	6.1	8.3	10.9	17.0	24.5
7	0.8	1.7	3.2	5.0	7.1	9.7	12.7	19.8	28.6
8	0.9	2.0	3.6	5.7	8.2	11.1	14.5	22.7	32.6
9	1.0	2.3	4.1	6.4	9.2	12.5	16.3	25.5	36.7
10	1.1	2.6	4.5	7.1	10.2	13.9	18.1	28.3	40.8
11	1.3	2.8	5.0	7.8	11.2	15.3	20.0	31.2	44.9
12	1.4	3.1	5.4	8.5	12.2	16.7	21.8	34.0	49.0
13	1.5	3.3	5.9	9.2	13.3	18.1	23.6	36.8	53.1
14	1.6	3.6	6.3	9.9	14.3	19.4	25.4	39.7	57.1
15	1.7	3.8	6.8	10.6	15.3	20.8	27.2	42.5	61.2
16	1.8	4.1	7.3	11.3	16.3	22.2	29.0	45.3	65.3
17	1.9	4.3	7.7	12.0	17.3	23.6	30.8	48.2	69.4
18	2.0	4.6	8.2	12.8	18.4	25.0	32.6	51.0	73.5

<b>Table 2 - Buoyancy of a Sphere</b>			
(Weight of the sphere has been neglected)			
Diameter Inches	Buoyancy Lbs.	Diameter Inches	Buoyancy Lbs.
2.0	0.15	8.0	9.68
3.0	0.51	8.5	11.61
4.0	1.21	9.0	13.78
4.5	1.72	9.5	16.21
5.0	2.37	10.0	18.91
5.5	3.15	10.5	21.89
6.0	4.08	11.0	25.17
6.5	5.19	11.5	28.76
7.0	6.49	12.0	32.67
7.5	7.98		

**Option 2. Splitter Basin: (The following is one example of a splitter basin) (See Figure 5)**

**Description:** Return flow from the recirculating gravel filter is directed through a splitter basin where a percentage of flow returns to the recirculating/mixing tank and a percentage to the soil dispersal component. The typical percentage split is 80% to the mixing tank and 20% to the soil dispersal component. The line to soil dispersal component must be equipped with an automatic (usually electrically actuated) valve which closes when a low liquid level in the recirculating/mixing tank is reached (during periods of low flow) directing all of the flow into the recirculating/mixing tank.

*Note: To assure uniform splitting in the basin, it is critical that the basin and pipes within the basin are installed level. To better assure that the basin is installed level, the basin should be placed on compacted base material or concrete slab. Additionally, uniform splitting in the basin is better assured when the basin is partially flooded to a level submerging the splitting orifices. This is best accomplished if the return flow from the recirculating gravel filter is pumped from the filter to the basin rather than by gravity flow. Overflow “tees” are installed within the basin in each of the lines (line to final disposal and line to mixing tank). The overflow “tees” allow for an approximate equal split of flows in the event the basin is filling faster than the exit flow through the splitting orifices. If a pump is utilized to return flow to the basin, to prevent complete flooding of the basin, the dose volume must not exceed the capacity of the basin or the overflow pipes. Top of the overflow “tees” should be set to a level that allows the basin to fill without overflowing into the “tees” under typical operating conditions. (This is a function of dose volume and pump flow)*

**Figure 7 - Splitter Basin**

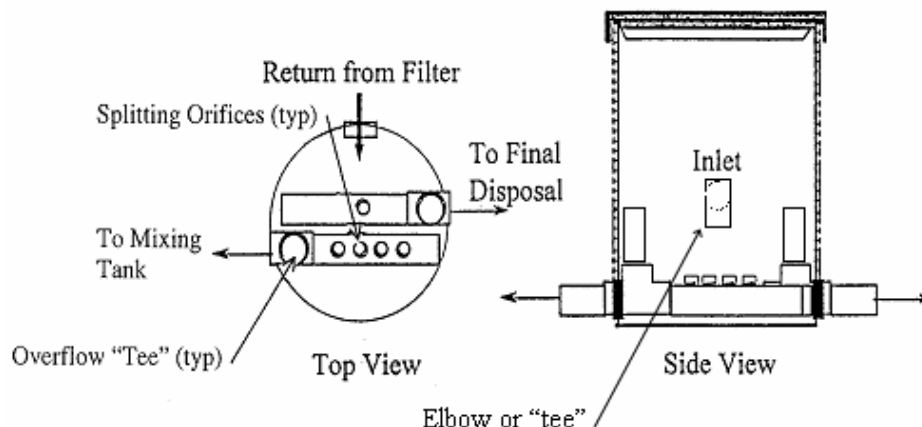

**Option 3. Gravity Flow From the Recirculating/Mixing Tank Without the Use of Splitting Devices:**

**Description:** With this concept, all of the return flow from the filter is directed back to the recirculating mixing tank where it mixes with influent from the septic tank. An outlet sanitary tee is installed in the recirculating mixing tank at approximately 80% of the liquid capacity of the mixing tank. Once the liquid level is reached in the mixing tank, effluent is allowed to exit the mixing tank to final disposal. No splitting devices are utilized.

The timer settings on the recirculation pump control the recirculation rate to the filter. The splitter device is the component that directs or divides the treated wastewater from the filter back to the recirculating/mixing and/or to final disposal. The splitter device assures that during periods of peak flow, mixed effluent from the recirculating/mixing tank will only exit the tank by passing through the recirculating gravel filter one more time prior to disposal. It is possible to design a recirculating gravel filter system without the use of a splitter device. However, designing without a splitter device may lower the expected levels of treatment under certain conditions.

Considerable discussion regarding this concept was conducted by the TRC. Due to little known experience with this concept at this time, the impact of not using a splitter device is unknown. If this concept is utilized, the following are recommended and/or strongly encouraged:

- Extending the influent sanitary tee deeper into the tank to maximize mixing with recirculated effluent.
- An effluent sampling program to verify that the performance standards are being met.
- “Pump fail” alarm in the control panel.

**Appendix E - Inspection / Monitor Ports**

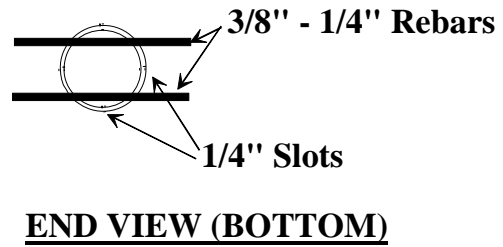
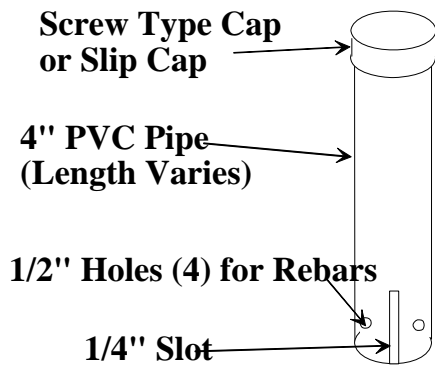
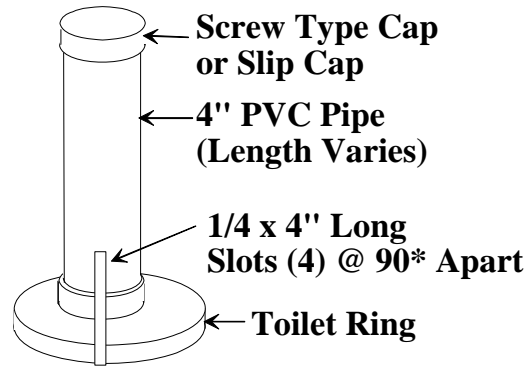
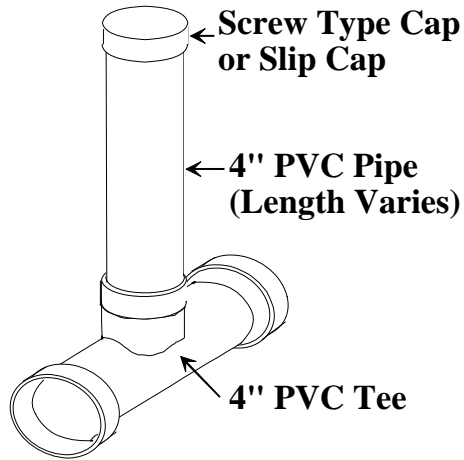

## Appendix F - Disposal of Contaminated Filter Media

Whenever filter media is removed from a used filter, removing and disposing of contaminated filter media is to be done in a manner approved by the local health officer. Handle this material carefully by using adequate protective sanitation measures. Thoroughly wash hands and any other exposed skin with hot water and soap, following contact with contaminated sand filter media.

This material may be applied to the soil, according to the following, only when approved by the local health officer.

APPLICATION	RESTRICTIONS/TIMETABLE
1. Root crops, low-growing vegetables, fruits, berries used for human consumption.	Contaminated material must be stabilized and applied 12 months prior to planting.
2. Forage and pasture crops for consumption by dairy cattle.	Forage and pasture crops not available until one month following application of stabilized material.
3. Forage and pasture crops for consumption by non-dairy livestock.	Forage and pasture crops not available until two weeks following application of stabilized material.
4. Orchards or other agricultural area where the material will not directly contact food products. Or where stabilized material has undergone further treatment, such as pathogen reduction or sterilization.	Less severe restrictions may be applicable.

## **Appendix G - Bibliography**

Boyle, W.C. and Richard J. Otis, "On-Site Treatment", EPA Training Manual, Prepared for Environmental Research Information Center, ORD, USEPA, July 1979.

Design Manual: On-site Wastewater Treatment and Disposal Systems. U.S. EPA, EPA-625/1-80-012 October 1980

Final Report, Oregon On-site Experimental Systems Program, December 1982; Oregon Department of Environmental Quality

Glossary of Water and Wastewater Control Engineering; Joint Editorial Board of the AWWA, WPCF, ASCE, APHA, Copyright 1969

Gross, Mark A., Optimum Depth of Sand for Filtering Septic Tank Effluent; Masters Degree Thesis, Master of Science, University Of Arkansas, 1981.

Gross, Mark, Dee T. Mitchell, Biological Virus Removal from Household Septic Tank Effluent; Proceedings of the Fourth National Symposium on Individual and Small Community Sewage Systems, ASAE, December 1984, New Orleans, Louisiana.

Gross, Mark, Ph.D., P.E., Dee Mitchell, Household Wastewater Virus Removal by Sand Filtration; 1988 Revision.

Hathaway, Randy J., Dee T. Mitchell, Sand Filtration of Septic Tank Effluent For All Seasons Disposal By Irrigation, Proceedings of the Fourth National Symposium on Individual and Small Community Sewage Systems, December 1984, New Orleans, Louisiana

Hines, Michael and R.E. Favreau, Recirculating Sand Filter: An Alternative to Traditional Sewage Absorption Systems, Proceedings of National Home Sewage Disposal Symposium, December 1974.

Loudon, T.L., G.L. Birnie, Jr., Performance of Trenches Receiving Sand Filter Effluent in Slowly Permeable Soils, Proceedings of the 6th National Symposium on Individual and Small Community Sewage Systems, ASAE, December, 1991, Chicago, IL.

Management of Small Waste Flows, Final Report of the Small Scale Management Project, University of Wisconsin, EPA 600/2-78-173.

Mitchell, Dee, Sand Filtration of Septic Tank Effluent, Proceedings of the 5th Northwest On-site Wastewater Treatment Short Course, University of Washington, September 1985

Mitchell, Mike D. P.E., Writings, Northwest Septic, Inc., Mt. Vernon, Washington.

On the Performance of Experimental Sand Filters in the State of Oregon, Oregon Department of Environmental Quality.

Koerner, Robert M., Ph.D., P.E., Designing with Geosynthetics, Prentice-Hall

Otis, Richard, P.E., Soil Clogging: Mechanisms and Control, Proceedings of the 4th National Symposium on Individual and Small Community Sewage Systems, ASAE, December 1984, New Orleans, LA.

Otis, Richard J., P.E., On-site Wastewater Treatment Intermittent Sand Filters, Rural Systems Engineering, Madison, Wisconsin.

Sauer, D.K., W.C. Boyle, and Richard J. Otis. "Intermittent Sand Filtration." ASCE/EE, August 1976

Scherer, Billy P., Dee T. Mitchell, Individual Household Surface Disposal of Treated Wastewater without Chlorination; Proceedings of the Third National Symposium on Individual and Small Community Sewage Treatment, December 1981, Chicago, Illinois.

Siegrist, Robert L., Hydraulic Loading Rates for Soil Absorption Systems Based on Wastewater Quality, Proceedings of the 5th National Symposium on Individual and Small Community Sewage Systems, ASAE, December 1987, Chicago, IL

Technology Assessment of Intermittent Sand Filters. U.S. EPA, Office of Municipal Pollution Control, Project Officer: James F. Kreissl. Authors: Damann L. Anderson, Robert L. Seigrist, Richard J. Otis.

Tyler, E. Jerry, James C. Converse, Soil Acceptance of Onsite Wastewater as Affected by Soil Morphology and Wastewater Quality, Proceedings of the 7th International Symposium on Individual and Small Community Sewage Systems, ASAE, December 1994, Atlanta, GA.

Louden, Ted L., Design of Recirculating Sand Filters, Proceedings of the 8th Northwest On-Site Wastewater Treatment Short Course and Equipment Exhibition, University of Washington Department of Civil Engineering, September 1995, Seattle, WA.

Ball, Jeffrey L., Grant D. Denn., Design of Recirculating Sand Filters Using a Standardized Methodology, Proceedings of the 9th Northwest On-Site Wastewater Treatment Short Course and Equipment Exhibition, University of Washington Department of Civil Engineering, September 1997, Seattle, WA.

Bounds, T.R. PE, Design Criteria for Recirculating Sand Filters, July 7, 1998.

Standard Specifications for Road, Bridge, and Municipal Construction, Washington State Department of Transportation, 1998.